



EBARA

CH1102VE

MULTI STAGE PUMP

Model MS, MSL·MSH

50Hz



Applications & Features

Applications

- Water supply
- Hot/cold water circulation
- Sprinklers
- Agriculture
- Construction
- Factories
- Mines
- Boiler feed
- Other general high pressure services
- Please select the model, referring to specifications for each model.

Features

1. EBARA's unique double volute construction provides higher operating efficiency over a wider range of capacities than conventional pumps equipped with guide vanes.
2. Simple construction of the pumps contributes to longer service life. The pumps are compact, lightweight and they operate with minimum noise.
3. Double volute casing is designed to balance radial force at all ranges of operation. Axial force is absorbed by a balance-disk which has a wear indicator at the shaft end.
4. Parts are fully standardized to ensure easy servicing and maintenance.
5. The pumps are designed so as not to exceed rated horse power at any pumping quantity. (Model MS)

General selection chart

50Hz

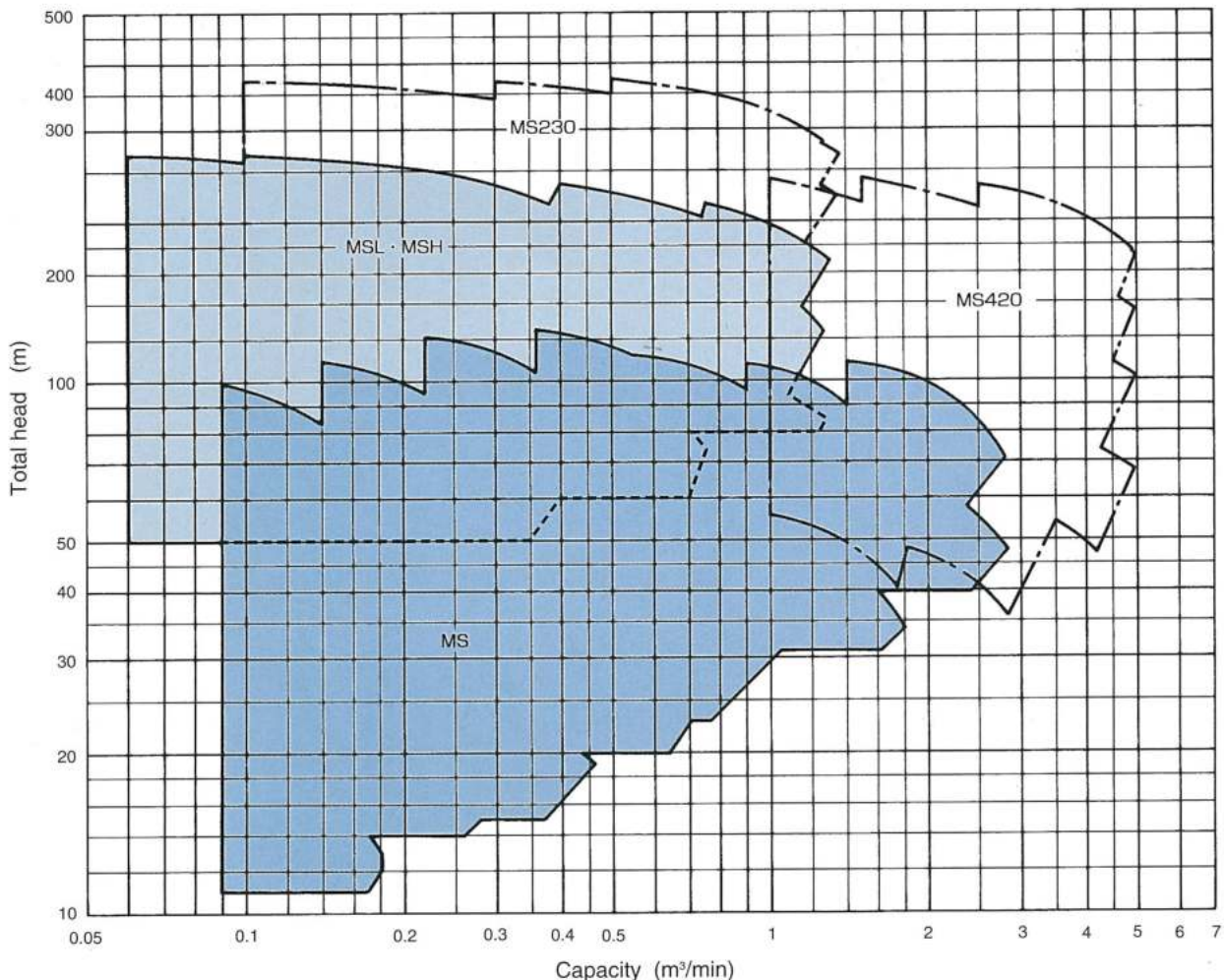

Sectional view

Model MS(balancing disk type)

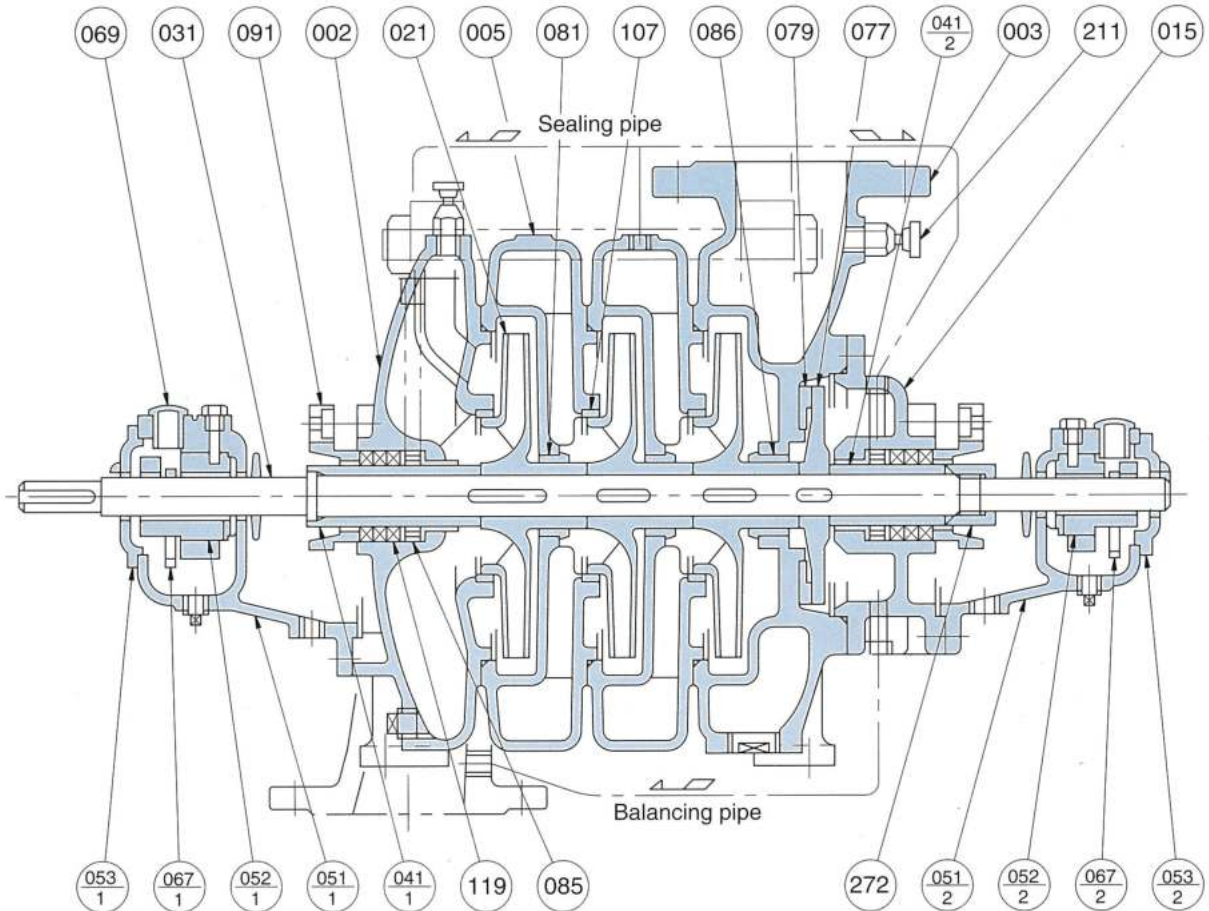

Construction may vary somewhat according to the model.

Part No.	Part Name	No. for 1 Unit
002	Suction Casing	1
003	Discharge Casing	1
005	Interstage Casing	N-1
015	Cover of Balancing Chamber	1
021	Impeller	N
031	Shaft	1
041-1	Saft Sleeve	1
041-2	Saft Sleeve	1
051-1	Bearing Housing	1
051-2	Bearing Housing	1

Part No.	Part Name	No. for 1 Unit
052-1	Bearing Metal	1
052-2	Bearing Metal	1
053-1	Bearing Cover	1
053-2	Bearing Cover	1
067-1	Oil Ring	1
067-2	Oil Ring	1
069	Oil Sight	2
077	Balancing Disk	1
079	Balancing Disk Seat	1
081	Interstage Bushing	N-1

Part No.	Part Name	No. for 1 Unit
085	Lantern Ring Bushing	2
086	Balancing Bushing	1
091	Gland	2
107	Casing Ring	N
119	Packing	6
211	Air Vent Valve	2
272	Sleeve Nut	1

Note: *N* indicates the number of stages in the pump.

Features of double volute construction

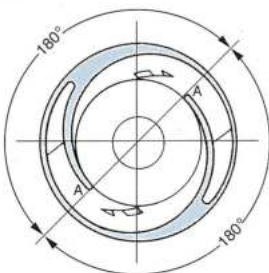

1. As shown in the drawing, water flow is divided into two equal parts by "tongues" A and A' located 180° apart. This produces a symmetrical flow to the section which is at right angles to the shaft and rationally balances radial thrust on the rotor.
2. Basic studies and experiments determined that shape and contour of vortex must introduce vertical flow directly to the impeller of next stage. This feature, plus the meticulously designed three dimensional impellers, enables Model MS pumps to achieve incomparable efficiency.
3. Casing configuration, which is narrower than that of conventional multistage pumps, contributes to the design of a light-weight, compact double volute pump.

Model MS (4pole moter drive)

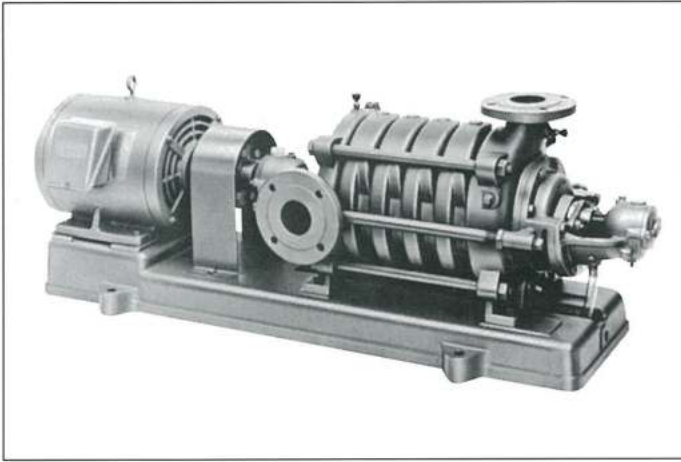

Construction	Enclosed	Shaft seal: [Balancing disk type]
Impeller	Gland packing	External flushing
Shaft seal	[Balancing disk type] Sleeve bearing (Lubricant oil)	Bearing: [Balancing disk type]
Bearing	[Ball bearing type] Sealed ball bearing	Ball bearing
		Outdoor use
Flange	JIS 10K thin type	
Suction side	[Balancing disk type]	
Discharge side	JIS10K thin type or JIS10K normal type [Ball bearing type]	
	JIS 10K thin type	
Materials	Cast iron	Shaft: 403 Stainless steel
Casing	304 Stainless steel: 40MS, 50MS	304 Stainless steel
Impeller	Bronze: 65MS to 150MS	Shaft sleeve: 304 Stainless steel
Shaft	Carbon steel	
Shaft sleeve	Bronze	
Motor	Three phase, 4 pole, 1.5 to 55kw	
Location	Indoors	
Accessories	[Bare shaft pump] Priming plug or priming funnel ... 1 Companion flange with bolts...1set	Foot valve Vibration absorber Flexible pipe Anchor bolts
	[Pump with motor] Common base 1 Priming plug or priming funnel ... 1 Coupling 1set Coupling guard 1 Companion flange with bolts...1set	

Specifications

	Standard	Option
Liquid	Fresh water 0 ~ 80°C	81~100°C
Total suction head	-6m at 20°C, max. capacity of selection chart	
Max. suction pressure	0.4MPa {4kgf/cm ² }	

Selection chart

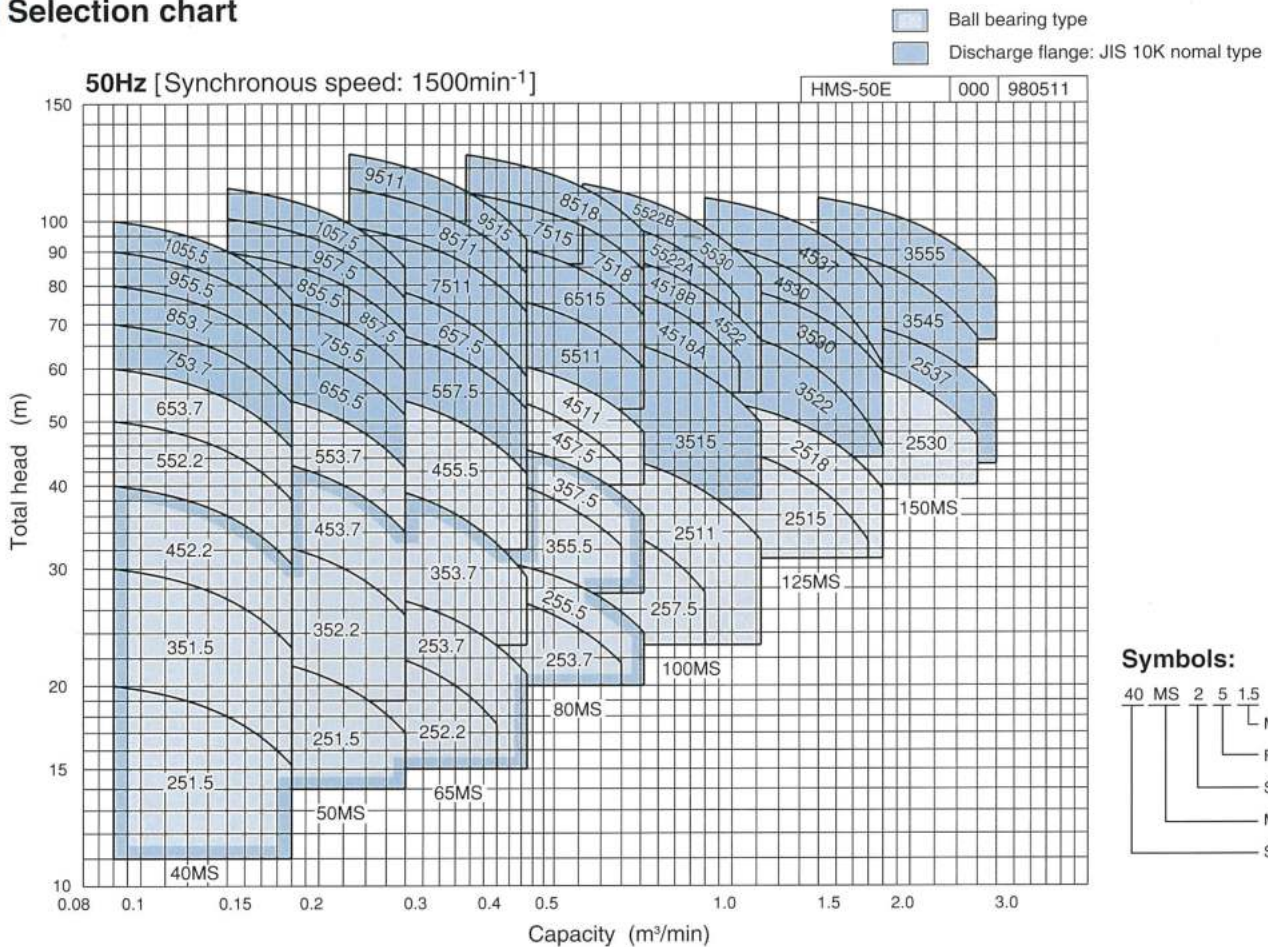

Model MSL MSH (2pole moter drive)

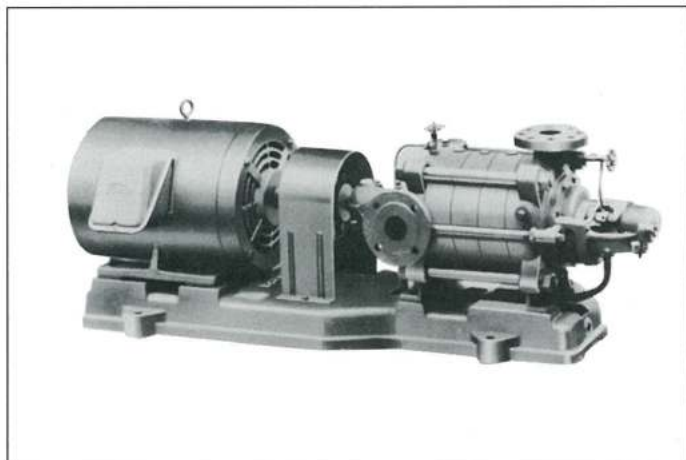

Construction	Impeller: Enclosed Shaft seal: Gland packing Bearing: Sleeve bearing (Lubricant oil)	Water cooling jacket Bearing, Stuffing box (81-120°C) Shaft seal: External flushing Outdoor use
Flange	Suction side: JIS10K normal type Discharge side: JIS10K normal type: MSL JIS20K: MSH	
Materials	Casing: Cast iron Ductile cast iron(MSH discharge casing only) Impeller: Bronze Shaft: Carbon steel Shaft sleeve: Bronze	Shaft: 420 Stainless steel Shaft sleeve: 420Stainless steel All iron
Motor	Three phase, 2pole, 3.7 to 75kw	
Location	Indoore	
Accessories	[Bare shaft pump] Nil [Pump with motor] Common base 1 Coupling 1set Coupling guard 1 Air vent valve 2	Welding type companion flange (SS) Foot valve Priming funnel Suction strainer with short pipe Heat preventive orifice with T pipe Vibration absorber Flexible pipe Anchor bolts

Specifications

	Standard	Option
Liquid	Fresh water 0 ~ 80°C	81~120°C
Total suction head	-6m at 20°C, max. capacity of selection chart	
Max. suction pressure	(Refer to selection chart.)	

Selection chart

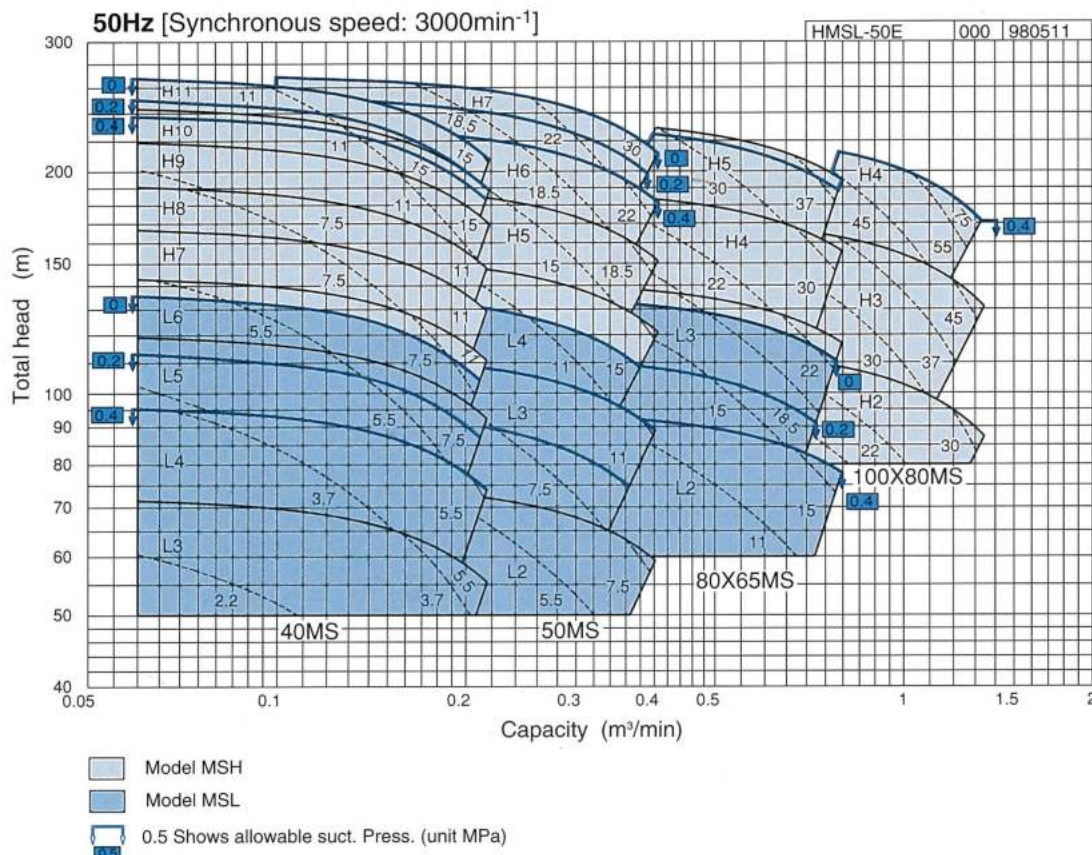

■ Dimensions

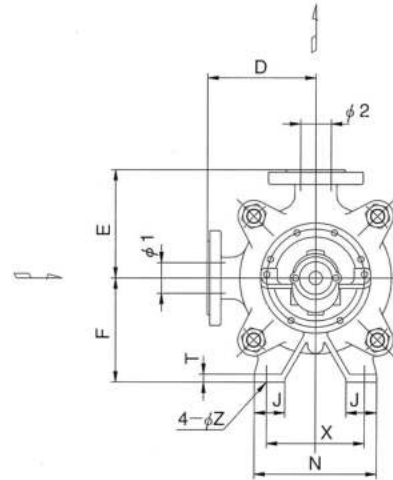
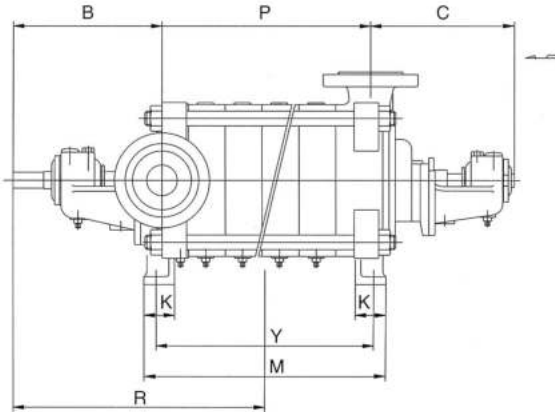

Unit: mm

Flange

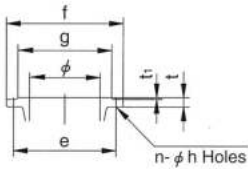

Shaft end

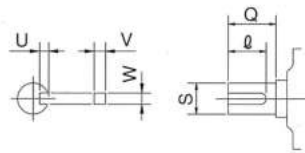

Model		Flange						
		g	e	f	t	t ₁	n	h
40MSL	Suction	85	105	140	20	2	4	19
	Discharge	85	105	140	20	2	4	19
40MSH	Suction	85	105	140	20	2	4	19
	Discharge	85	105	140	22	2	4	19
50MSL	Suction	100	120	155	20	2	4	19
	Discharge	100	120	155	20	2	4	19
50MSH	Suction	100	120	155	20	2	4	19
	Discharge	100	120	155	22	2	8	19
80×65MSL	Suction	130	150	185	22	2	8	19
	Discharge	120	140	175	22	2	4	19
80×65MSH	Suction	130	150	185	22	2	8	19
	Discharge	120	140	175	24	2	8	19
100×80MSH	Suction	155	175	210	24	2	8	19
	Discharge	135	160	200	26	2	8	23

Unit: mm

Suction size $\phi 1$	Discharge size $\phi 2$	Model	Stage	Pump														Shaft						
				B	C	D	E	F	J	K	M	N	P	R	T	X	Y	Z	S	Q	ℓ	U	V	W
40	40	MSL	3	248	230	160	160	150	50	50	262	200	200	337	13	160	222	12	20	45	40	3.0	5	5
		MSL	4	248	230	160	160	150	50	50	317	200	255	364.5	13	160	277	12	20	50	40	3.0	5	5
		MSL	5	248	230	160	160	150	50	50	372	200	310	392	13	160	332	12	20	50	40	3.0	5	5
		MSL	6	248	230	160	160	150	50	50	427	200	365	419.5	13	160	387	12	20	50	40	3.0	5	5
		MSH	6	248	230	160	160	150	50	50	427	200	365	419.5	13	160	387	12	20	50	40	3.0	5	5
		MSH	7	248	230	160	160	150	50	50	482	200	420	447	13	160	442	12	20	56	50	3.0	5	5
		MSH	8	248	230	160	160	150	50	50	537	200	475	474.5	13	160	497	12	20	56	50	3.0	5	5
		MSH	9	248	230	160	160	150	50	50	592	200	530	502	13	160	552	12	20	56	50	3.0	5	5
		MSH	10	248	230	160	160	150	50	50	647	200	585	529.5	13	160	607	12	20	56	50	3.0	5	5
		MSH	11	248	230	160	160	150	50	50	702	200	640	557	13	160	662	12	20	56	50	3.0	5	5
		50	50	MSL	2	243	235	175	175	170	50	50	215	200	160	320.5	13	160	175	12	26	45	40	4.0
MSL	3			243	235	175	175	170	50	50	275	200	220	350.5	13	160	235	12	26	45	40	4.0	7	7
MSL	4			243	235	175	175	170	50	50	335	200	280	380.5	13	160	295	12	26	50	40	4.0	7	7
MSH	4			243	235	175	175	170	50	50	335	200	280	380.5	13	160	295	13	26	50	40	4.0	7	7
MSH	5			243	235	175	175	170	50	50	395	200	340	410.5	13	160	355	12	26	50	40	4.0	7	7
MSH	6			243	235	175	175	170	50	50	455	200	400	440.5	13	160	415	12	26	50	40	4.0	7	7
MSH	7			243	235	175	175	170	50	50	515	200	460	470.5	13	160	475	12	26	56	50	4.0	7	7
80	65	MSL	2	260	245	210	210	180	55	60	252	240	190	354	15	190	212	15	32	56	50	4.5	8	10
		MSL	3	260	245	210	210	180	55	60	322	240	260	389	15	190	282	15	32	56	50	4.5	8	10
		MSH	3	260	245	210	210	180	55	60	322	240	260	389	15	190	282	15	32	56	50	4.5	8	10
		MSH	4	260	245	210	210	180	55	60	392	240	330	424	15	190	352	15	32	56	50	4.5	8	10
		MSH	5	265	245	210	210	180	55	60	462	240	400	464	15	190	422	15	32	63	50	4.5	8	10
100	80	MSH	2	291	275	230	230	200	70	70	295	250	225	398.5	18	190	235	19	36	63	50	4.5	8	10
		MSH	3	291	275	230	230	200	70	70	380	250	310	441	18	190	320	19	36	71	50	4.5	8	10
		MSH	4	291	275	230	230	200	70	70	465	250	395	483.5	18	190	405	19	36	71	50	4.5	8	10

 **CAUTION**

- Do not attempt to operate, inspect or service this pump before you have read and understood manual of pump.
- Wiring and grounding work must NOT be performed by unqualified persons. It is extremely dangerous for unqualified persons to perform such work. The user should install electrical leakage breakers and overload safety devices to prevent electric shock and fire.

*All specifications subject to change without notice.



EBARA CORPORATION

Standard Products Business Office (Japan)

Phone: 81-3-5461-6101 Fax: 81-3-5460-4930

Website: <http://www.ebara.co.jp>

Ebara Engineering Singapore Pte. Ltd. (Singapore)

Phone: 65-6862-3536 Fax: 65-6861-0589

Ebara Middle East Branch Office (U.A.E.)

Phone: 971-4-8838889 Fax: 971-4-8835307

©EBARA CORP. 2004 Printed in Japan.

Printed on recycled paper

35-030-E05
0833⑤JC-C(AA)Da