

GRUNDFOS DPK RANGE, 50 Hz
High pressure, installation flexibility and ease of service



SUBMERSIBLE DRAINAGE PUMPS FOR A RANGE OF APPLICATIONS



be
think
innovate

GRUNDFOS 

HIGH PRESSURE AND RELIABLE DRAINAGE PUMPS

– designed for your varied needs

The DPK range of submersible drainage pumps from Grundfos provides surface water drainage, combining installation flexibility and high-pressure capabilities with reliability and ease of service.

The DPK range presents a surprisingly compact design, considering the pressure capabilities on offer. Together with the solid cast-iron construction and available installation options, the DPK range is perfect for drainage pit applications.

Flexibility characterizes the DPK range. Simply install the pump on an auto-coupling rail or use free-standing with a flexible hose or flange connection for an incredibly easy to service, cost-effective drainage solution.



EFFECTIVE DRAINAGE – when and where you need it

If you're working with building services, courts drainage, or with any application requiring reliable drainage, the DPK range will remove all rainwater and ground water.

The DPK range ensures quality, cost-effective drainage

- Underground drainage pits in buildings, where the need for high pressure and ease of service matches the combination of motor size and pressure capabilities offered by the DPK range.
- Courts drainage solutions, with similar requirements for high pressure and ease of service.
- Industrial applications, where water from various processes and functions is collected in drainage pits and then pumped onwards.



DPK PUMP FEATURES

– and what they offer you

Motor protection

Built-in bi-metal sensor protects against overheating.

Shaft seal

The double mechanical seal is positioned in the oil chamber and ensures trouble-free operation.

Easy maintenance oil plug

The ability to inspect oil condition in the seal chamber makes it easy for you to plan maintenance and service your pump.

Flange or hose connection

Depending on your requirements, the pump can be ordered with a hose or flange connection.

Auto-coupling or ring stand

Flexible submerged installation options increase versatility, with auto-coupling guide rails or free-standing options available.

Highly efficient impeller

The ductile cast iron impeller maintains its performance, ensuring an increased lifetime.

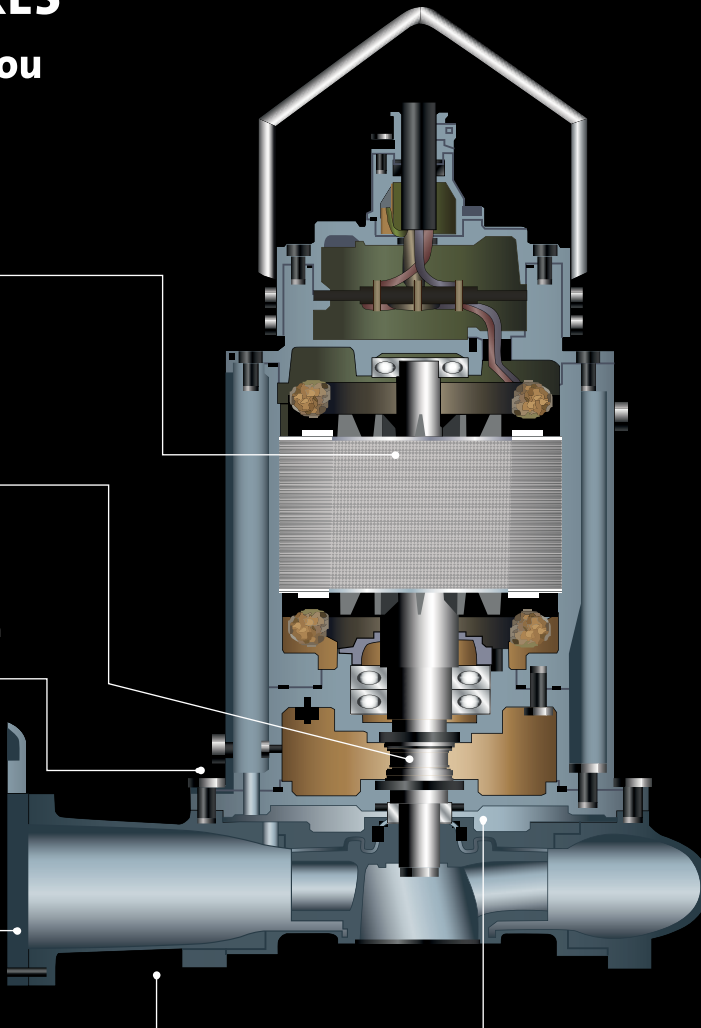

Performance overview

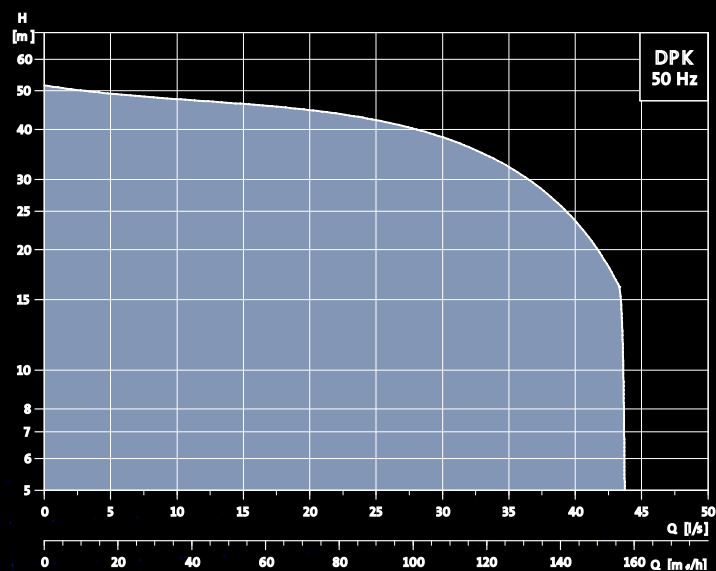

SEE THE BIGGER PICTURE

Grundfos is a global leader within water handling technology. Our passion is to bring you all the products you require to create and operate pump systems that combine reliability, cost-efficiency – and innovation. Our products are for use in water supply and wastewater infrastructure on any scale.

Grundfos has a full line of products and systems for the intake, treatment and distribution of drinking water and for the transport and treatment of wastewater. We also offer expertise and industry insight that can increase reliability and reduce lifecycle costs for water utilities.

Key product areas include:



Submersible pumps



Surface pumps



Sewage pumps



Mixers, flowmakers & recirculation pumps



Pumping stations



Monitoring & controls



Dosing & disinfection



Aeration equipment

Our products are the result of decades of engineering expertise. Supported by a worldwide service network. Visit grundfos.com/water-utility for more.