

ETA-N

Centrifugal Pumps



PT TORISHIMA GUNA INDONESIA

GENERAL

ETA.N series are industrial pumps of back pull out design according to JIS B8313.

APPLICATIONS

- General water supply, irrigation and drainage
- Pumping of sea water, brine, alkali and condensate
- Circulating hot and cold water supply
- Sprinkling & fire fighting system
- Swimming Pool

DESIGN

- End suction volute pumps with vertical centerline discharge
- Back Pull Out (BPO) design allows the removal all rotating elements without disturbing the casing, piping or motor

MATERIAL EXPLANATION

Bronze of BC2 or BC6 quality is recommended for sea water application or other corrosive media

IMPELLER

- Closed, radial flow impeller fitted with protective wear ring
- Balanced hydraulically
- Trimming of impeller is possible

BEARINGS

- Permanent lubricated grease ball bearings
- Oil lubricated bearing (*see option*)

SHAFT SEALS

- Strong stuffing boxes
- Single acting mechanical seal are available

FLANGES

- JIS 10 k F.F
- Optional with other flanges connection standard

DRIVE

Electric motors and engines are also available on request

DIRECTION OF ROTATION

Clockwise viewed from the drive end



PUMP SPECIFICATION

SPECIFICATION		STANDARD	OPTION *
CAPACITY		Up to 620 m ³ /h (170 l/s)	
TOTAL HEAD		Up to 100 m	
Product Temperature		-10 °C to 100 °C	-30 °C - 120 °C
Pump Discharge Pressure		Up to 10 bar	
Pump Size		32 mm to 150 mm	
MATERIAL	Volute Casing	Cast Iron FC250	Ductile FCD400 / Bronze BC6
	Casing Cover	Cast Iron FC250	Ductile FCD400 / Bronze BC6
	Bearing Housing	Cast Iron FC250	
	Impeller	Cast Iron FC200	Ductile FCD400 / Bronze BC6
	Shaft	Martensitic Steel SUS420J2	SUS316/SUS304
	Casing Wear Ring	Cast Iron FC200	Bronze BC6
	Impeller Wear Ring	Cast Iron FC200	Bronze BC6
	Shaft Protection Sleeve	Martensitic Steel SUS420J2	Austenitic Steel SUS304 / 316
Seal	Gland Packing	Mechanical Seal	
Ball Bearing	Deep Groove	Open type	
Lubrication	Grease	Oil	

* all material combination within above mentioned material specification is possible

SECTIONAL DRAWING & LIST COMPONENT

PART NO.	PART DESIGNATION	MATERIAL	QTY
1020	Volute Casing	FC 250	1
1610	Casing Cover	FC 250	1
1830	Support Foot	SS 400	1
2100	Shaft	SUS 420J2	1
2300	Impeller	FC 200	1
3210.1	Ball Bearing	No. 63 - C3	1
3210.2	Ball Bearing	No. 63 - C3	1
3300	Bearing Housing	FC 250	1
3600.1	Bearing Cover	ADC 12	1
3600.2	Bearing Cover	ADC 12	1
4000.1	Flat Gasket	Valqua 6500	1
4000.2	Flat Gasket	Valqua 6500	1
4000.3	Flat Gasket	Valqua 6500	1
4230.1	Labyrinth Ring	Plastic	1
4230.2	Labyrinth Ring	Plastic	1
4520	Gland	FC 200	1
4540	Gland Bush	FC 200	1
4580	Lantern Ring	FC 200	1
4610	Gland Packing	Non Asbestos	3
5020	Casing Wearing	FC 200	1
5030	Impeller Wearing	FC 200	1
5240	Shaft Protecting Sleeve	SUS 420J2	1
5500	Washer Impeller *	SUS 304	1
9021	Gland Bolt	SUS 304	2
9201	Fine Hexagonal Nut	SS 400	1
9300	Spring Washer	SUS 304	1
9400.1	Key	S45C	1
9400.2	Key **	S45C	1

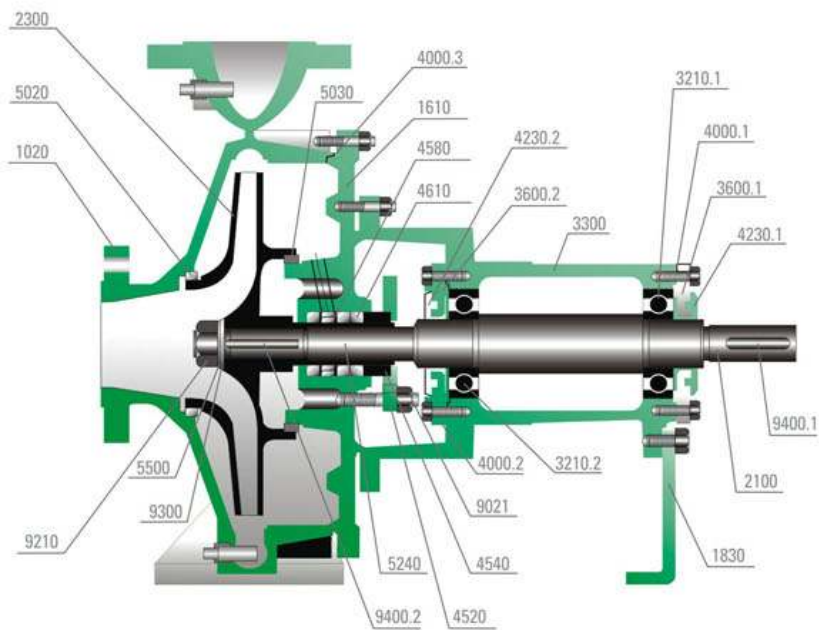

* Only use on Pump size with code (*)

** There are 2 size (each size 1 pc/unit pump) for Pump size with code (**)

OUTLINE DRAWING

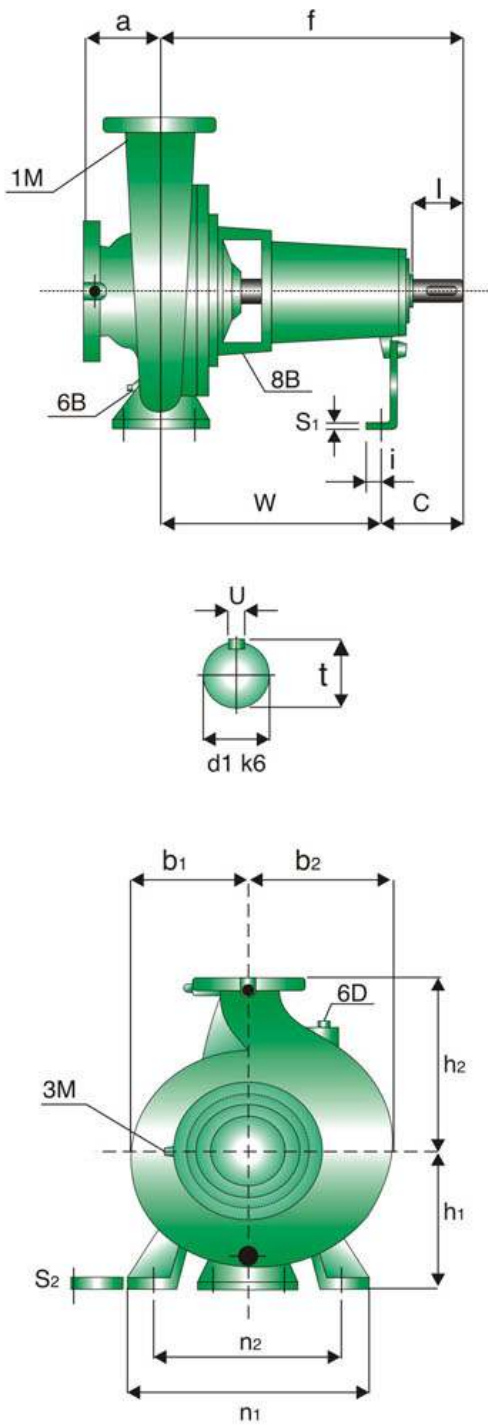

AUXILIARY CONNECTION

SYMBOL	DESIGNATION
1 M	Pressure Measurement Instrument
3 M	Pressure Measurement Instrument
6 B	Casing Drain
6 D	Printing and Venting
8 B	Leakage Drain
10 E	Sealing Liquid Inlet
11 E	Flushing Liquid Inlet

PUMP SIZE	1 M	6 B	8 B	10 E
	3 M	6 D		11 E
	DIMENSION			
50 x 32 - 160				
50 x 32 - 200				
50 x 40 - 200				
50 x 40 - 250				
50 x 40 - 315.1				
65 x 50 - 160				
65 x 50 - 200				
65 x 50 - 250				
65 x 50 - 315.1				
80 x 65 - 160		PT 3/8		
80 x 65 - 200				
80 x 65 - 250				
80 x 65 - 315.1				
100 x 80 - 125				
100 x 80 - 160				
100 x 80 - 200				
100 x 80 - 250				
100 x 80 - 315.1	PT 3/8		PT 1/2	PT 3/8
100 x 80 - 400.1				
125 x 100 - 160		PT 1/2		
125 x 100 - 200				
125 x 100 - 200.1		PT 3/8		
125 x 100 - 250		PT 1/2		
125 x 100 - 250.1		PT 3/8		
125 x 100 - 315				
125 x 100 - 400				
150 x 125 - 200				
150 x 125 - 250				
150 x 125 - 315		PT 1/2		
150 x 125 - 400				
200 x 150 - 200				
200 x 150 - 250				
200 x 150 - 315				
200 x 150 - 400				



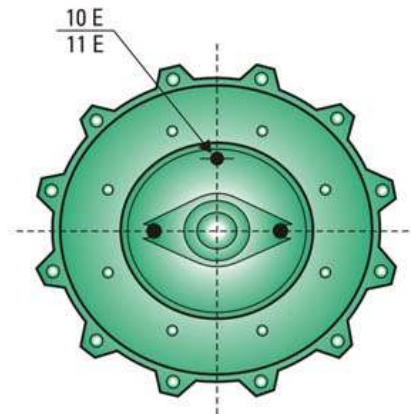
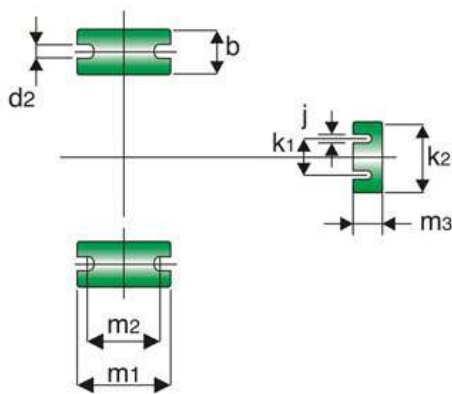

PUMP FLANGE DIMENSION (acc. to JIS 10 kgf / cm²F.F)

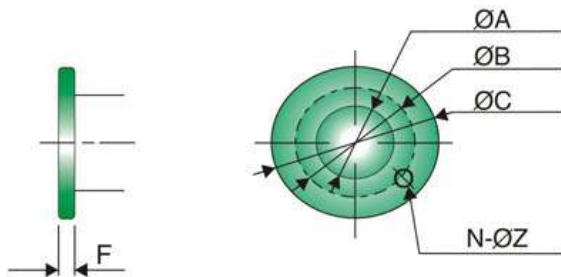

dimension in mm

ND	ØA	ØB	ØC	F	N-ØZ
32	32	100	135	20	4 - 19
40	40	105	140	20	4 - 19
50	50	120	155	20	4 - 19
65	65	140	175	22	4 - 19
80	80	150	185	22	8 - 19
100	100	175	210	24	8 - 19
125	125	210	250	24	8 - 23
150	150	240	280	26	8 - 23
200	200	290	330	26	12 - 23

PUMP SIZE	PUMP DIMENSION											FOOT DIMENSION											SHAFT END DESIGN				
	DN 1	DN 2	a	b1	b2	f	h1	h2	b	C	d2	i	m1	m2	m3	j	k1	k2	n1	n2	S1	S2	W	d1k6	l	t	u
50x32-160*	50	32	80	116	125	360	132	160	50	103	16	25	100	70	50	15	110	160	240	190	4	15	257	24	50	27	8
50x32-200*	50	32	80	128	137	360	160	180	50	103	16	25	100	70	50	15	110	160	240	190	4	18	257	24	50	27	8
50x40-200*	50	40	80	132	141	360	160	180	50	103	16	25	100	70	50	15	110	150	240	190	4	18	257	24	50	27	8
50x40-250*	50	40	100	170	176	350	180	225	65	109	16	25	125	95	50	15	110	160	320	250	4	18	251	32	50	35	8
50x40-315.1*	50	40	125	194	203	470	225	250	65	132	16	25	125	95	50	15	110	160	345	280	6	18	338	32	80	35	10
65x50-160*	65	50	80	115	131	360	132	160	50	103	16	25	100	70	50	15	110	160	240	190	4	15	257	24	50	27	8
65x50-200*	65	50	100	133	147	360	160	180	50	103	16	25	100	70	50	15	110	160	265	212	4	15	257	24	50	27	8
65x50-250*	65	50	100	165	178	360	180	225	65	109	16	25	125	95	50	15	110	160	320	250	4	18	251	32	50	35	8
65x50-315.1*	65	50	125	200	216	470	225	280	65	132	16	25	125	95	50	15	110	160	345	280	6	18	338	32	80	35	10
80x65-160*	80	65	100	125	147	360	160	180	50	103	16	25	100	70	50	15	110	160	265	212	4	15	257	24	50	27	8
80x65-200*	80	65	100	145	165	360	160	200	50	103	16	25	100	70	50	15	110	150	265	212	4	15	257	32	50	35	8
80x65-250*	80	65	100	168	184	360	180	225	65	109	16	25	125	95	50	15	110	160	320	250	4	18	251	32	50	35	8
80x65-315.1*	80	65	125	208	229	470	225	280	80	132	21	25	160	120	50	15	110	160	400	315	6	20	338	32	80	35	10
100x80-125*	100	80	100	120	148	360	160	180	65	103	16	25	125	95	50	15	110	160	280	212	4	18	257	32	50	35	8
100x80-160*	100	80	100	130	158	360	160	200	85	103	16	25	125	95	50	15	110	150	280	212	4	18	257	32	50	35	8
100x80-200*	100	80	100	164	177	360	180	225	65	109	16	25	125	95	50	15	110	160	320	250	4	18	251	32	50	35	8
100x80-250	100	80	100	180	200	470	200	250	80	132	21	25	160	120	50	15	110	160	360	280	6	20	338	32	80	35	10
100x80-315.1	100	80	125	220	244	470	250	315	80	132	21	25	160	120	50	15	110	160	400	315	6	20	338	32	80	35	10
100x80-400.1**	100	80	125	253	276	530	280	355	80	192	21	25	160	120	50	15	110	160	435	355	6	20	338	42	115	45	12
125x100-160	125	100	125	178	225	470	200	250	80	132	21	25	160	120	50	15	110	160	360	280	6	18	338	32	80	35	10
125x100-200	125	100	125	173	213	470	200	280	80	132	21	25	160	120	50	15	110	160	360	280	6	18	338	32	80	35	10
125x100-200.1	125	100	125	161	189	470	180	250	65	132	16	25	125	95	50	15	110	150	345	280	4	18	338	32	80	35	10
125x100-250	125	100	140	190	220	470	225	280	80	132	21	25	160	120	50	15	110	160	400	315	6	20	338	32	80	35	10
125x100-250.1	125	100	125	184	210	470	225	280	80	132	21	25	160	120	50	15	110	160	400	315	6	18	338	32	80	35	10
125x100-315	125	100	140	225	255	470	250	315	80	132	21	25	160	120	50	15	110	160	400	315	6	20	338	32	80	35	10
125x100-400**	125	100	140	253	280	530	280	355	100	161	26	25	200	150	50	15	110	160	500	400	6	20	369	42	115	45	12
150x125-200	150	125	140	195	244	470	250	315	80	132	21	25	160	120	50	15	110	160	400	315	6	20	338	32	80	35	10
150x125-250	150	125	140	229	275	470	250	355	80	132	21	25	160	120	50	15	110	160	400	315	6	20	338	32	80	35	10
150x125-315**	150	125	140	238	278	530	280	355	100	192	26	25	200	150	50	15	110	160	500	400	6	20	338	42	115	45	12
150x125-400**	150	125	140	275	305	530	315	400	100	161	26	25	200	150	50	15	140	200	500	400	6	20	369	42	115	45	12
200x150-200	200	150	160	238	315	470	280	400	100	132	26	25	200	150	50	15	110	160	550	450	6	20	338	32	80	35	10
200x150-250**	200	150	160	228	298	530	280	375	100	192	26	25	200	150	50	15	110	160	500	400	6	20	338	42	115	45	12
200x150-315**	200	150	160	255	303	530	315	400	100	161	26	25	200	150	50	15	140	200	550	450	6	20	369	42	115	45	12
200x150-400**	200	150	160	285	325	530	315	450	100	161	26	25	200	150	50	15	140	200	550	450	6	20	359	42	115	45	12

SELECTION CHART

50Hz-2P n=2900 1/min

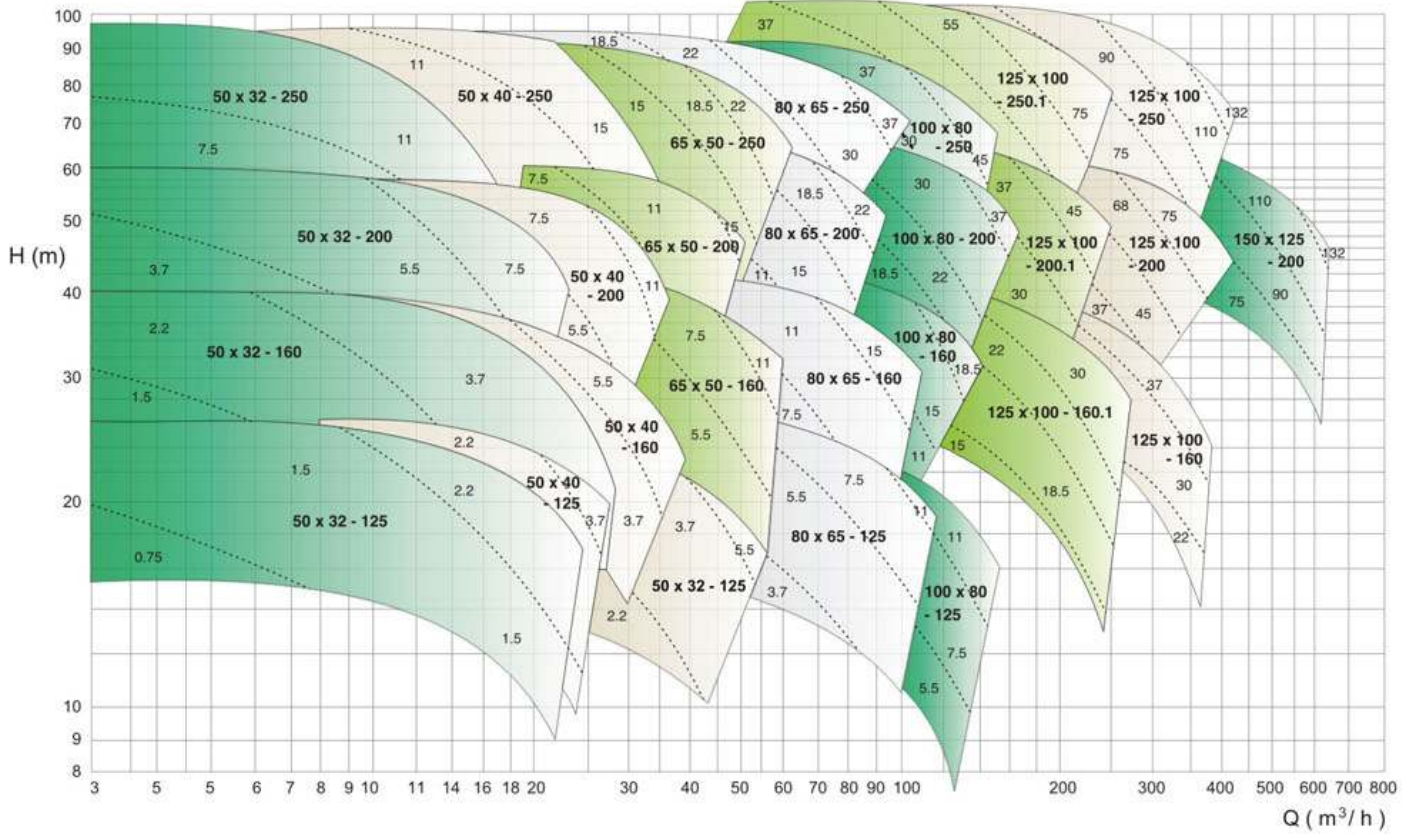

50Hz-4P n=1450 1/min

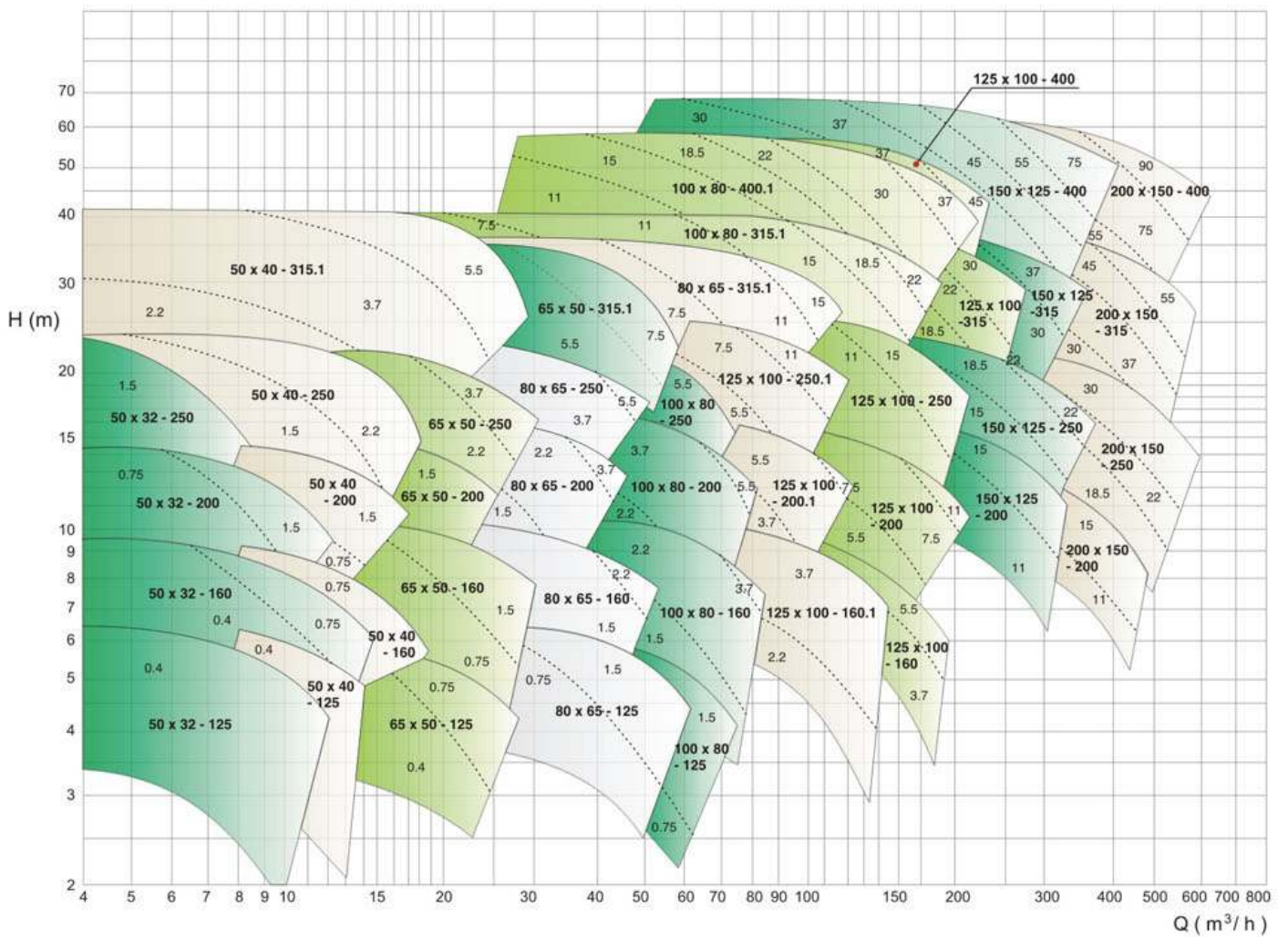

60Hz-2P n=3500 1/min

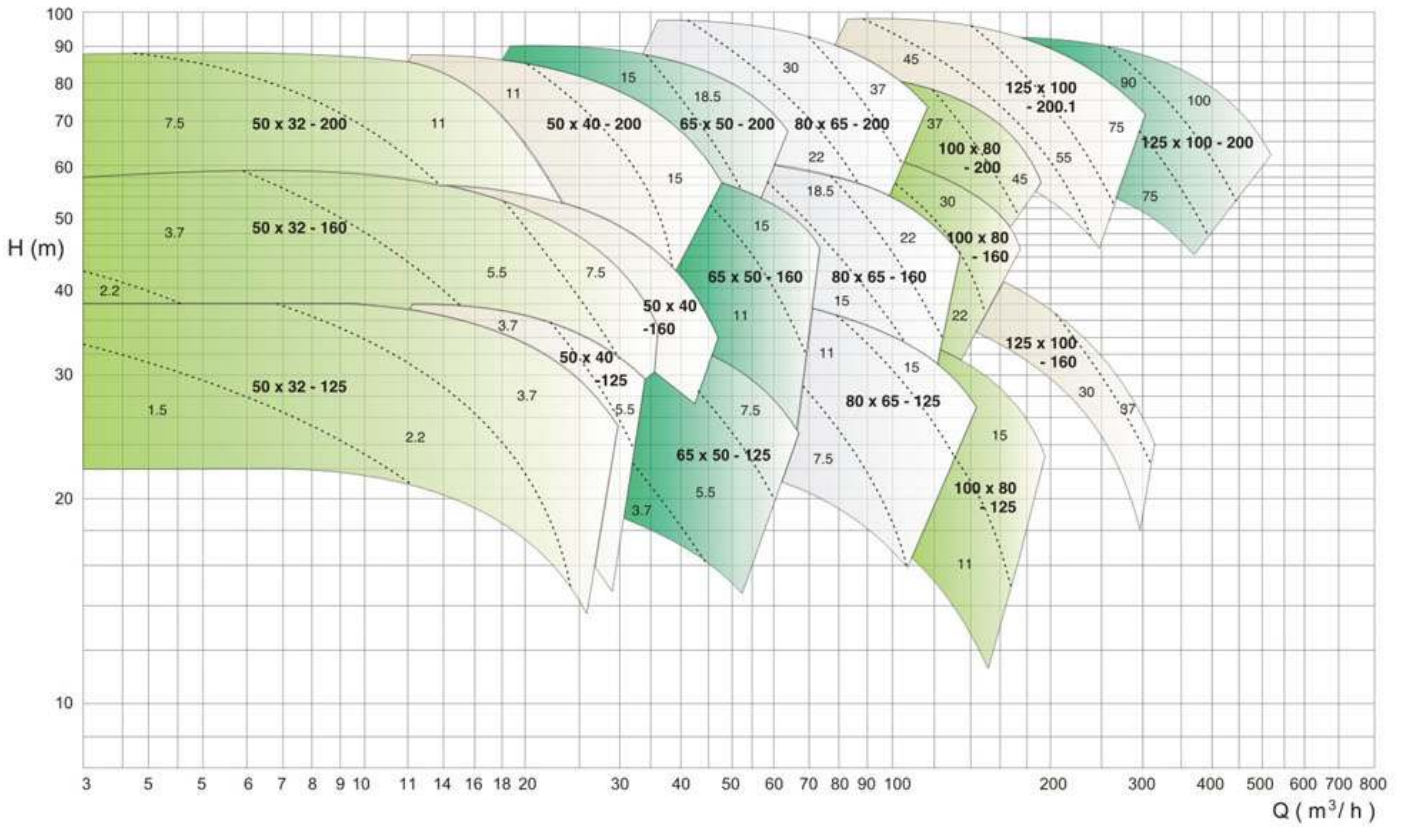

60Hz-4P n=1750 1/min

