

MMO

Centrifugal Pumps



PT TORISHIMA GUNA INDONESIA

GENERAL

TORISHIMA MMO, is a high pressure centrifugal pumps are pumps of ring section type. They are suitable for clean media free from abrasive and solid particles and not liable to attack the pump mechanically (*abrasion*) or chemically (*corrosion*).

APPLICATIONS

They are used in waterworks, pressure boosting stations, sprinkling and irrigation installations, fountains, fire-fighting systems and in mechanical engineering. They handle boiler feedwater and condensate, circulate cooling water and hotwater and are used for power water generation and in carwashes.

PERFORMANCE RANGE

Capacity : up to 36 l/s (130 m³/h)
 Total Head : up to 400 m
 Operation Pressures : up to 40 bar
 Operating Temperatures : - up to +110 °C (GP)
 - up to +120 °C (MS)

MMO pumps can also be used as circulating pumps in high pressure systems because even the suction casing is designed for 40 bar.

The only restriction is that the sum of the maximum suction pressure plus total head must not exceed 40 bar at zero capacity.

THOROUGHLY RATIONALIZED DESIGN TO MEET ANY SPECIFIED REQUIREMENTS

Simple and high performance design contributes to reduction of equipment cost and energy-saving

Hydrodynamically simplified pump design resulted in attractive cost reduction. Besides not only the number of stages is lower but also pump size is smaller maintaining the same performance as our former models.

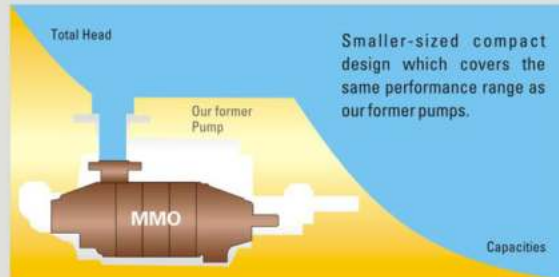

Shaft seal requires no cooling for temperature range up to 120 °C

Elimination of cooling water feed and return piping and monitoring instruments.

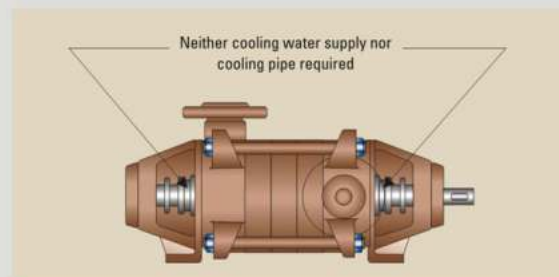

Nozzle orientation can be freely chosen

The pump feet, integrally cast onto the bearing housings, allow free orientation of both suction and discharge nozzles, as illustrated on the right.

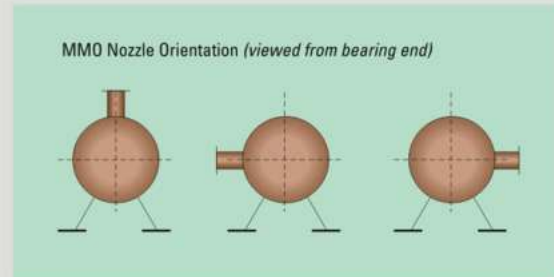

Variety of material combination

Various materials are available, so as to provide wide application range.

| MATERIAL COMBINATION | |
|------------------------------|--|
| Part Designation | Materials |
| Suction Casing, Stage Casing | Cast Iron, Bronze |
| Discharge Casing | Cast Iron, Bronze, Carbon Steel, Ductile Cast Iron |
| Impeller | Cast Iron, Bronze |
| Shaft | Carbon Steel, Stainless Steel |
| Shaft Protecting Sleeve | Stainless Steel |

SECTIONAL DRAWING & LIST COMPONENTS

* typical drawing only

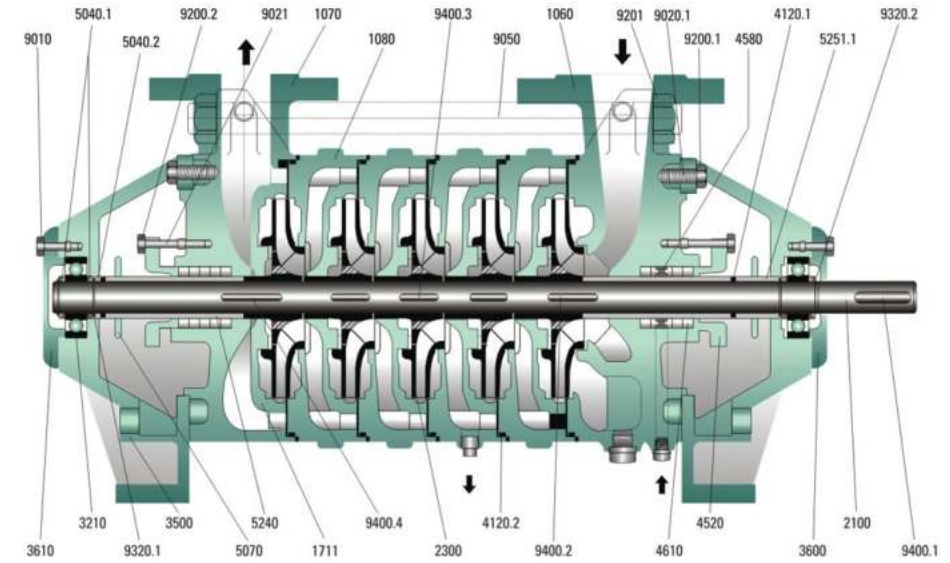

| PART NO. | PART DESIGNATION | MATERIAL | PART NO. | PART DESIGNATION | MATERIAL |
|----------|----------------------|-----------------|----------|------------------|----------|
| 1060 | Suction Casing | FC250 | 5070 | Deflector | S45C |
| 1070 | Discharge Casing | FC250 | 5240 | Packing Sleeve | SUS420J2 |
| 1080 | Stage Casing | FC250 | 5251.1 | Suction Sleeve | FC200 |
| 1711 | Diffuser, Last Stage | FC200 | 9010 | Hexagonal Bolt | SS400 |
| 2100 | Shaft | SUS420J2 | 9020.1 | Stud Bolt | S45C |
| 2300 | Impeller | FC200 | 9021 | Gland Bolt | SUS304 |
| 3210 | Ball Bearing | NO.63--DDUC3 | 9050 | Tie Bolt | S45C |
| 3500 | Bearing Bracket | FC250 | 9200.1 | Hexagonal Nut | SS400 |
| 3600 | Bearing Cover | FC200 | 9200.2 | Hexagonal Nut | SUS304 |
| 3610 | Bearing End Cover | FC200 | 9201 | Hexagonal Nut | SS400 |
| 4120.1 | O-Ring | VITON | 9320.1 | Snap Ring | SK5 |
| 4120.2 | O-Ring | VITON | 9320.2 | Snap Ring | SK5 |
| 4520 | Gland | FC200 | 9400.1 | Key | S45C |
| 4580 | Lantern Ring | BC | 9400.2 | Key | S45C |
| 4610 | Gland Packing | Carbon Graphite | 9400.3 | Key | S45C |
| 5040.1 | Spacer Ring | FC200 | 9400.4 | Key | S45C |
| 5040.2 | Spacer Ring | FC200 | | | |

MECHANICAL SEAL

| PART NO. | DESIGNATION |
|----------|-------------------|
| 4000 | Flat Gasket |
| 4120.1 | O-ring |
| 4120.3 | O-ring |
| 4120.4 | O-ring |
| 4710 | Cover Seal |
| 4720 | Seal Face |
| 4724 | Seal Face Housing |
| 4750 | Stationary Seat |
| 4770 | Spring |
| 5241 | Shaft Sleeve |
| 9021 | Gland Bolt |

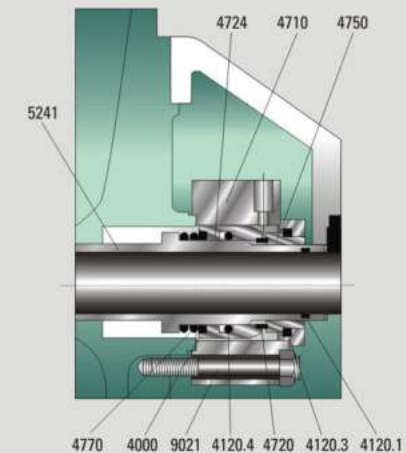

SELECTION CHARTS

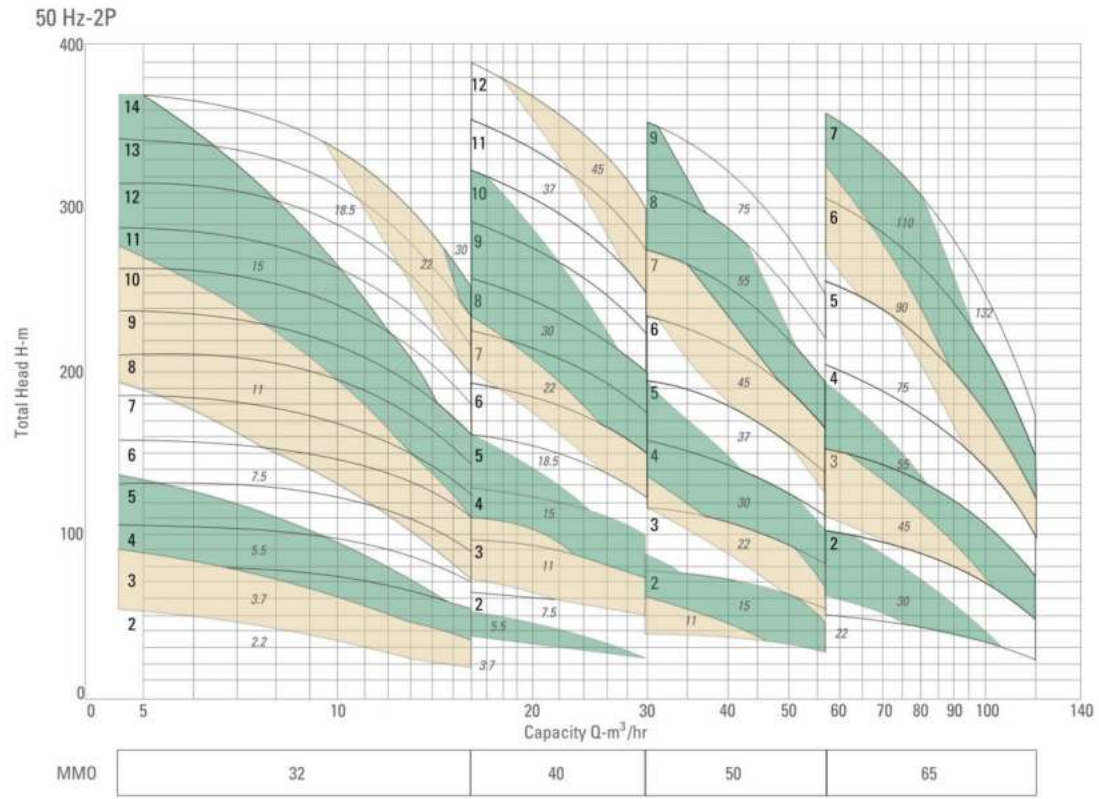

SELECTION CHARTS

