

TSURUMI UNIVERSE

NH 50Hz

SEWAGE PUMPS



TSURUMI UNIVERSE

“TSURUMI UNIVERSE” is a new brand of products from TSURUMI, a leading company in the field of submersible pumps for over 90 years. It has been developed to further spread TSURUMI products to markets around the world. Based on years of research and achievements, the brand was developed with the aim of enhancing competitiveness, while providing qualities equivalent to conventional models and TSURUMI’s original features and functions. Now, after thorough preparation, we are releasing our NH-series pumps under the new brand name of “TSURUMI UNIVERSE.”

Submersible Sewage Pumps

The NH-series pumps of the “TSURUMI UNIVERSE” brand are heavy-duty submersible sewage pumps made of cast iron. In addition to the wide range of specifications featuring 50 to 300 mm discharge bore diameters and 0.75 to 75 kW motor output capacities, the NH-series offers a variety of product lineups with three types of impellers: Channel, Cutter and Vortex types. The guide rail fitting device is applicable to all models, enabling easy installation and maintenance.

Equipped with a channel impeller, the NH and NHB series are TSURUMI’s basic type of pumps and provide excellent foreign object passage. The NHC-series features cutter pumps built with a combination of a channel impeller and a specially structured suction cover, in which a tungsten carbide alloy cutting edge is brazed to the impeller vane, thus enabling foreign objects to be shredded at the suction port while pumping. The NHU-series provides a semi-vortex structure equipped with a vortex impeller, whereby minimizing potential troubles caused by clogging of fibrous foreign objects.

The NH-series pumps are applicable to a wide spectrum of fields, such as raw water transfer in purifying tanks (Johkasou/septic tanks), wastewater treatment facilities, pumping stations and flood prevention equipment, and reservoirs of recreational facilities, as well as drainage of sewage and wastewater. These pumps integrate original technologies TSURUMI has perfected via years of research and achievements, to note our anti-wicking cable, dual inside mechanical seals with silicon carbide face, and Oil Lifter. In addition, with a design that thoroughly considers pump durability and wear resistance, these pumps enable continuous duty for a long period of time. TSURUMI products feature a highly reliable design that ensures excellent durability and stable quality, contributes to stable operations of facilities, and results in remarkably reduced maintenance costs.



Selection Table

		Sewage Pumps			
		NHB	NHC	NHU	NH
Discharge Bore	mm	100 – 300	50 • 80	50 • 80	50 – 150
Motor Output	kW	5.5 – 75	0.75 – 11	0.75 – 3.7	1.5 – 7.5
Pole		4	2	2	2
Impeller		Channel	Cutter (Channel Impeller with Cutting Edges)	Vortex	Channel
Flange Standard		DIN	JIS	JIS	JIS
Water Jacket		● (55 • 75kW only)			
Leakage Sensor		● (11 • 75kW only)			
Seal Pressure Relief Ports		● (22 – 75kW only)	● (5.5 – 11kW only)		● (5.5 • 7.5kW only)
Back Pull-out Design				● (2.2 • 3.7kW only)	
Guide Rail Fitting System		●	●	●	●
Page No.		7 - 8	9 - 10	11 - 12	13 - 14

IMPELLERS

Channel



The impeller is shrouded type with one or two vanes. It has a wide channel extending from inlet to exit, which allows the pump to pass the solid matters from inflow to discharge with minimal blockage.

Cutter



The impeller is a semi-open type with two vanes. Two sintered tungsten carbide alloy edges are brazed on two impeller vanes, and they rotate on a saw-tooth suction port of a suction cover. This mechanism allows to cut up the foreign matters flowed into the impeller to discharge them.

Vortex



The impeller is a vortex type. The rotation of the impeller produces a whirling, centrifugal action between the impeller and pump casing. Being coupled with a wide pump casing, even large solids and fibrous matters can be pumped out without obstruction.

Guide Rail Fitting System

The guide rail fitting system connects the pump to and from the piping easily just by lowering and hoisting the pump, allowing easy maintenance and inspection without the need to enter the sump. The TOS/TO is the guide rail fitting system made of cast iron and is compatible with cast iron pumps.

Accessories

- Duckfoot Bend
- Guide Support
- Guide Hook
- Lifting Chain 5m (with Shackles)
- JIS 10kg/cm² Flange or DIN PN6 Flange

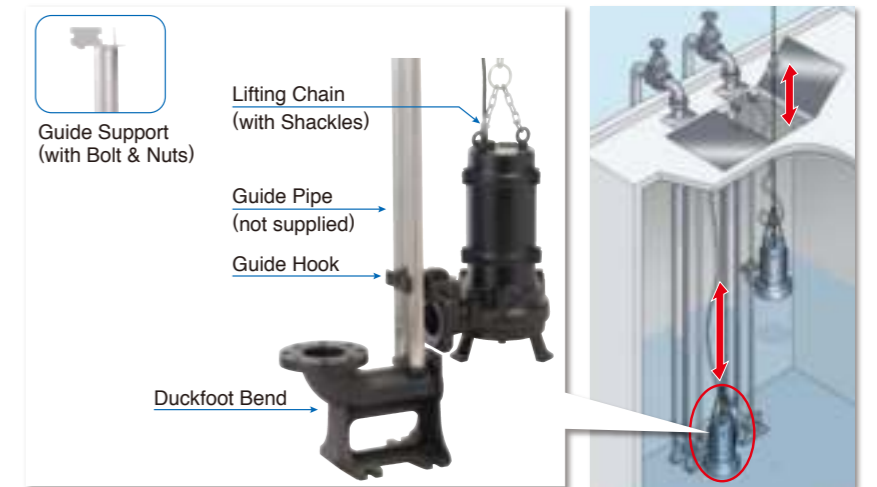

Model Number Designation

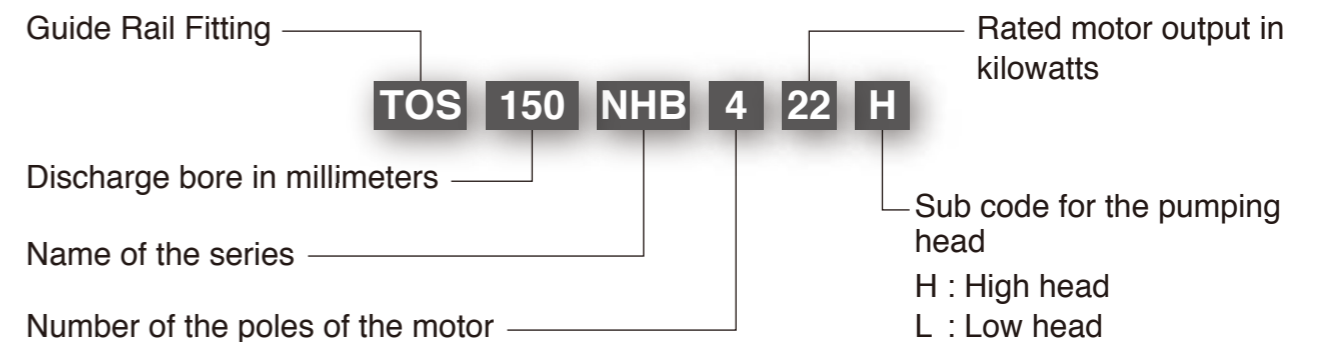

Float Switches

Tsurumi offers two types of float switches (liquid level sensors). A micro-switch is incorporated in both types.

Model MC-2 is a heavy-duty type float switch with a shock absorber. Having equipped with a high grade micro switch, the MC-2 assures trouble-free operation in the liquid containing much suspended solids and floating scum. Either of the two contacts, normally-open or normally-close, can be selected as required.



Model RF-5 is an economy type float which can detect upper/lower limit water levels with single float. The snap on-off action ensures stable operation in clean or waste water containing suspended solids or oil and fat.



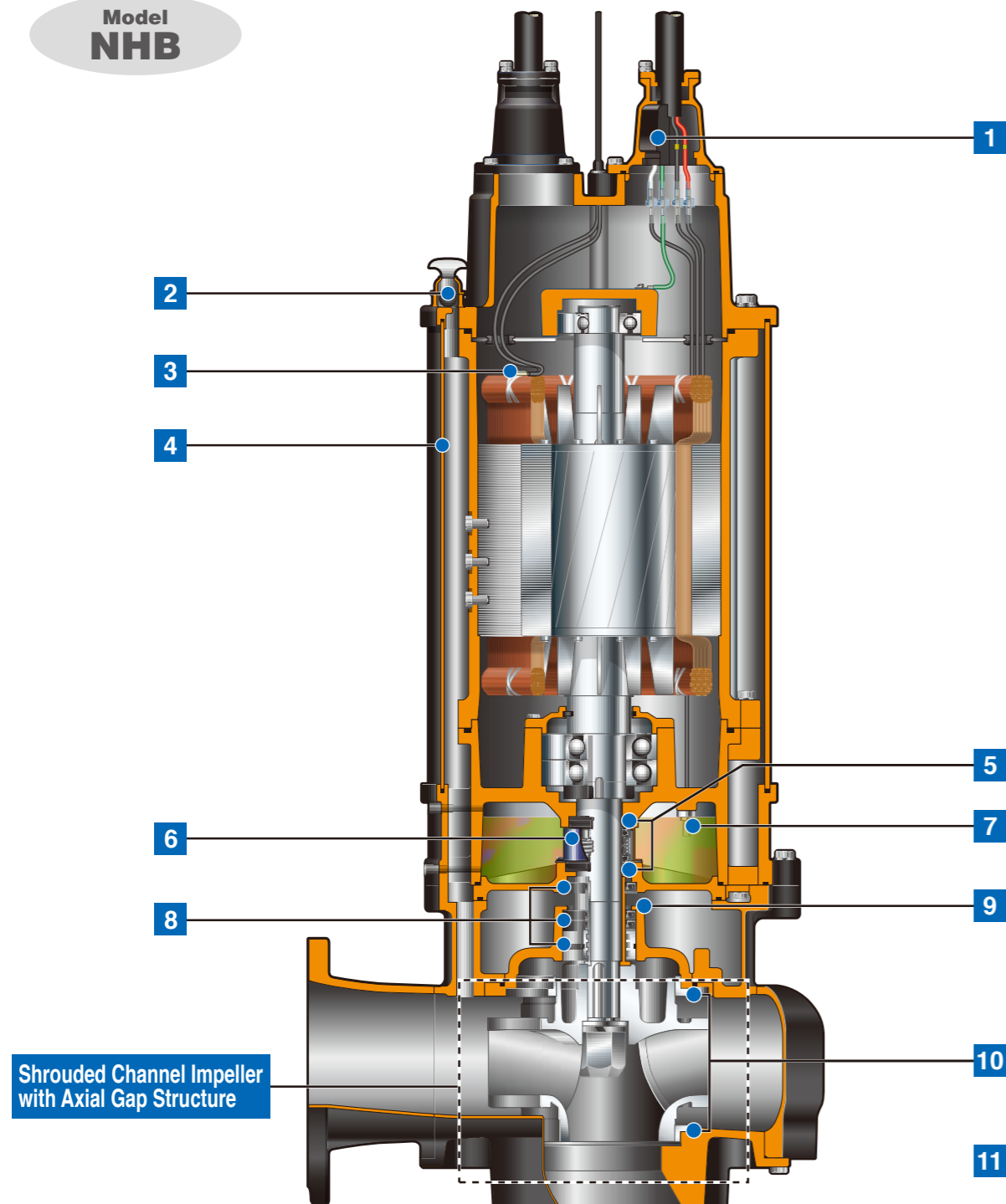

Shrouded Channel Impeller with Axial Gap Structure

1 Anti-wicking Cable Entry

Prevents water incursion due to capillary wicking should the power cable be damaged or the end submerged.

2 Air Release Valve *excluding some models

Fitted on the water jacket and/or the pump casing, it prevents the Air-lock. When air goes through the valve, the ball stays at the bottom, but when the pumped water starts to flow, it closes the outlet by its buoyancy.

3 Motor Protector

CTP (7.5kW and below)

Directly cuts the motor circuit if excessive heat builds up or overcurrent occurs in the motor.

MTP (11kW and above)

React to excessive heat caused by dry-running. The bimetal strip opens to cause the control panel to shut the power supply.

4 Water Jacket (NHB 55kW and above)

The pump is equipped with a water jacket, around the motor frame. A portion of the pumped liquid is allowed to flow into the water jacket to cool the motor. This design feature permits the unit to operate at low water levels for extended periods of time.

Shrouded Channel Impeller with Axial Gap Structure (NHB and NH)

* Some models consist of radial gap structure.

Tsurumi's sewage pumps have been developed on the following two design concepts.

- **Stable pump performance over long periods of time**
- **Improved maintainability and durability**

This axial gap structure is intended to prevent troubles caused by performance drop, cavitation and clogging due to ingested foreign objects, which may incur with pumps over extended operation.

The structure itself is formed by a closed type impeller and suction cover, and is adopted for many models of Tsurumi pumps to fulfill this purpose.

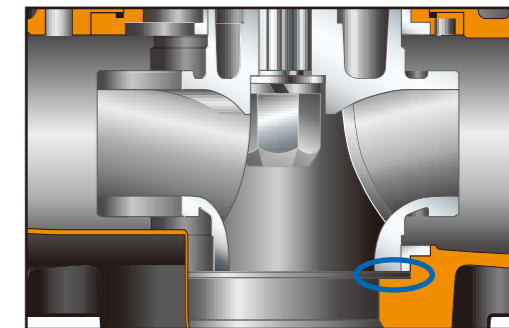

Feature

With the axial gap structure, the gap between the impeller and suction cover is perpendicular to the shaft. On the other hand, with a radial gap structure, the gap is parallel to the shaft.

In other words, assuming the same increase in gap width due to wear, pump performance drop of the axial gap structure is considerably smaller than that of the radial gap structure. With the axial gap structure, pump performance and efficiency can be maintained, even under impeller wear, by adjusting the gap between the impeller and suction cover with packing, etc. This reduces maintenance costs and ensures stable performance over long periods of time.

Furthermore, Tsurumi's own technical investigations and many years of research have shown the axial gap structure to be more advantageous against "clogging by fibrous materials," a problem that afflicts sewage pumps in general.

5 Dual Inside Mechanical Seals with Silicon Carbide Faces

Isolated in the oil chamber where a clean, non-corrosive and abrasion-free lubricating environment is maintained. Compared with the water-cooled outside mechanical seal, it reduces the risk of failure caused by dry-heating and adhering matter. The silicon carbide provides 5 times higher corrosion, wear and heat resistance than the tungsten carbide. Rubber parts of the upper and lower fixing rings are made of NBR or FPM (FKM), which provides higher resistance to heat and chemicals.

6 Oil Lifter [Patented]

Provides lubrication and cooling of the seal faces down to 1/3 of normal oil level, thus maintaining a stable shaft sealing effect and prolonging seal life longer.

7 Leakage Sensor (11kW and above)

Detects flooding into the oil chamber that may occur in a worst case scenario. When flooding is detected, signals are sent to operate the indicator lamps through the external control panel.

8 Single/Triple Oil Seals + Labyrinth Ring (NHB 55kW and above)

Used as a "Dust Seal", single or triple oil seals protect the mechanical seal from abrasive particles. The labyrinth ring is equipped to provide a better countermeasure against wear caused by high pressure generated in the casing and improve the maintainability for pumps of 55kW and above.

9 Seal Pressure Relief Ports (NH, NHC 5.5kW and above, and NHB 22kW and above)

Protect the mechanical seal from pump pressure. They also protect the seal face by discharging wear particles.

10 Mouth Ring & Wear Ring (NHB 30kW and above)

Prevent wear in the pump casing and suction cover, resulting in reduced maintenance costs.

11 Back Pull-out Design (NHU 2.2 & 3.7kW only)

Enables the motor to be separated from the pump unit with the impeller attached, by removing the bolts between the oil casing and the pump casing. This design facilitates maintenance and inspection of the principal parts of the pump.

NHB -Channel Impeller, 4-pole-

The NHB-series is a submersible channel impeller pump designed for handling raw sewage, wastewater and heavy-duty industrial applications, where the pump is subject to complete submersion and requires maximum reliability. A shrouded channel impeller practically prevents internal clogging and enables the pump to efficiently transfer sewage and wastewater containing solid matters. It is available as an extended line-up from 100 to 300mm discharge bores, 5.5 to 75kW.

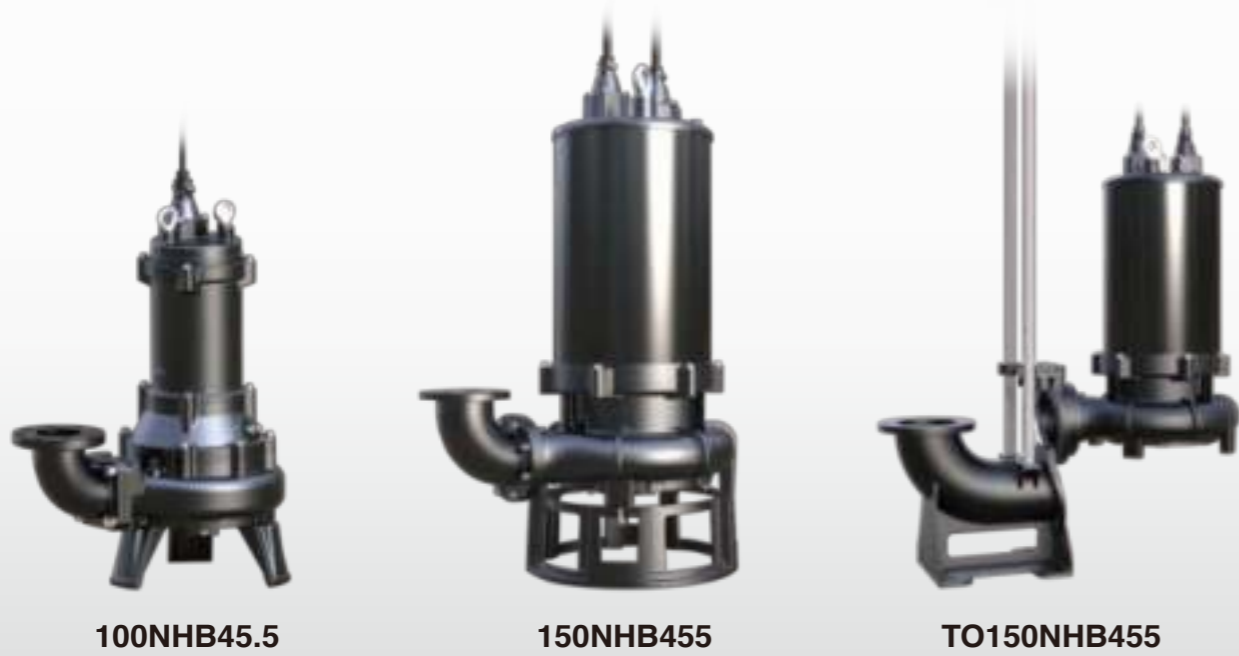

Discharge Bore mm	Model		Motor Output kW	Starting Method	Solids Passage mm	Dimensions L x H mm		Dry Weight* ³ kg		Cable Length m
	Free Standing	Guide Rail Fitting				Free Standing	Guide Rail Fitting	Free Standing	Guide Rail Fitting	
100	100NHB45.5	TOS100NHB45.5	5.5	D.O.L.* ¹	40	689 x 908	905 x 906	145	132	6
100	100NHB47.5	TOS100NHB47.5	7.5	D.O.L.* ¹	40	689 x 929	905 x 927	158	145	6
150	150NHB47.5L	TOS150NHB47.5L	7.5	D.O.L.* ¹	60	858 x 1085	1065 x 1030	221	192	6
150	150NHB411	TOS150NHB411	11	Star-Delta* ²	75	882 x 1097	1089 x 1052	243	213	8
150	150NHB415	TOS150NHB415	15	Star-Delta* ²	75	882 x 1167	1089 x 1122	259	234	8
150	150NHB422H	TOS150NHB422H	22	Star-Delta* ²	75	884 x 1281	1092 x 1241	347	317	8
150	150NHB422	TOS150NHB422	22	Star-Delta* ²	75	884 x 1282	1092 x 1241	347	317	8
150	150NHB437	TO150NHB437	37	Star-Delta* ²	40 x 50	1072 x 1567	1305 x 1399	547	486	8
150	150NHB455	TO150NHB455	55	Star-Delta	35 x 110	1120 x 1663	1391 x 1557	877	838	8
200	200NHB411	TO200NHB411	11	Star-Delta* ²	68 x 60	947 x 1113	1257 x 1078	262	257	8
200	200NHB415	TO200NHB415	15	Star-Delta* ²	70 x 60	925 x 1184	1235 x 1144	287	282	8
200	200NHB437	TO200NHB437	37	Star-Delta* ²	40 x 77	1191 x 1590	1429 x 1477	562	503	8
200	200NHB455	TO200NHB455	55	Star-Delta	40 x 70	1189 x 1663	1470 x 1627	912	875	8
200	200NHB475	TO200NHB475	75	Star-Delta	35 x 75	1189 x 1663	1470 x 1627	992	955	8
250	250NHB430	TO250NHB430	30	Star-Delta* ²	75 x 55	1296 x 1517	1567 x 1450	551	473	8
250	250NHB437	TO250NHB437	37	Star-Delta* ²	62 x 80	1296 x 1594	1567 x 1527	611	533	8
250	250NHB445	TO250NHB445	45	Star-Delta	45 x 70	1314 x 1556	1581 x 1497	711	620	8
250	250NHB475	TO250NHB475	75	Star-Delta	60 x 80	1384 x 1663	1702 x 1656	1050	995	8
300	300NHB445	TO300NHB445	45	Star-Delta	60 x 90	1349 x 1605	1673 x 1586	775	695	8

*¹ Star-Delta available upon request

*² D.O.L. available upon request

*³ All weights excluding cable
Weights of guide rail fitting excluding duckfoot bend

Performance Curves

It is not recommended to operate the unit continuously along the dashed curve.

< 100mm >

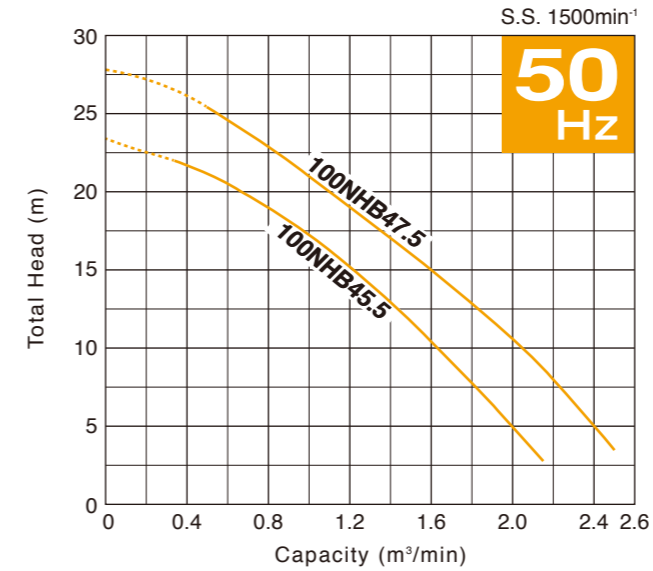

< 150mm >

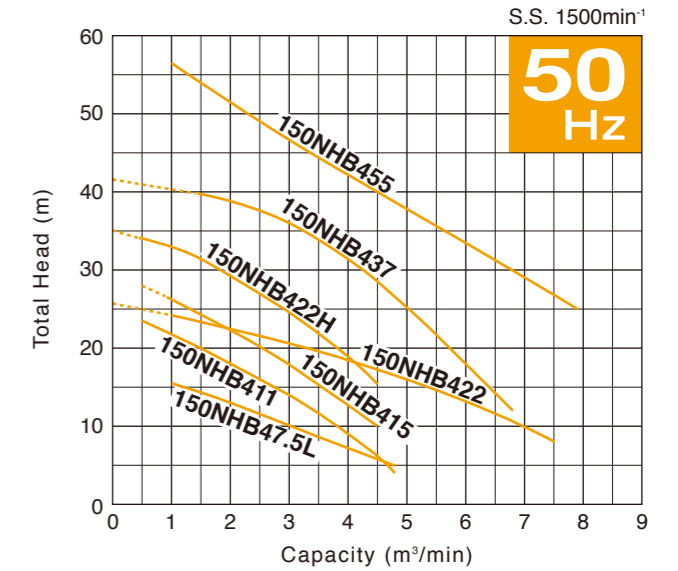

< 200mm >

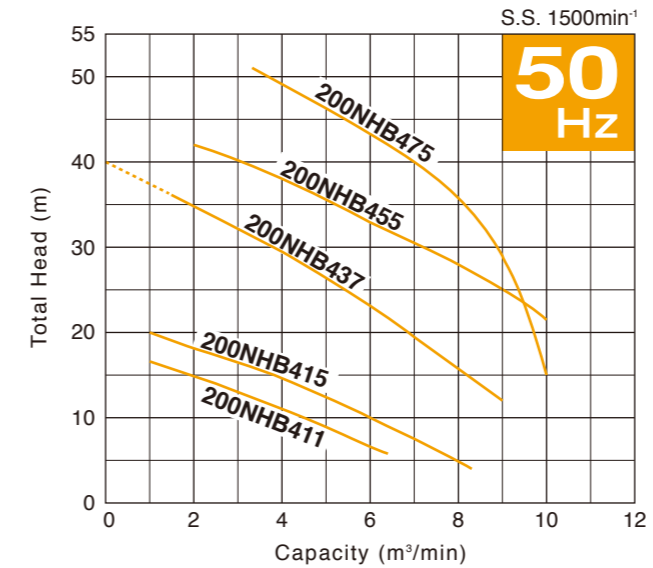

< 250mm >

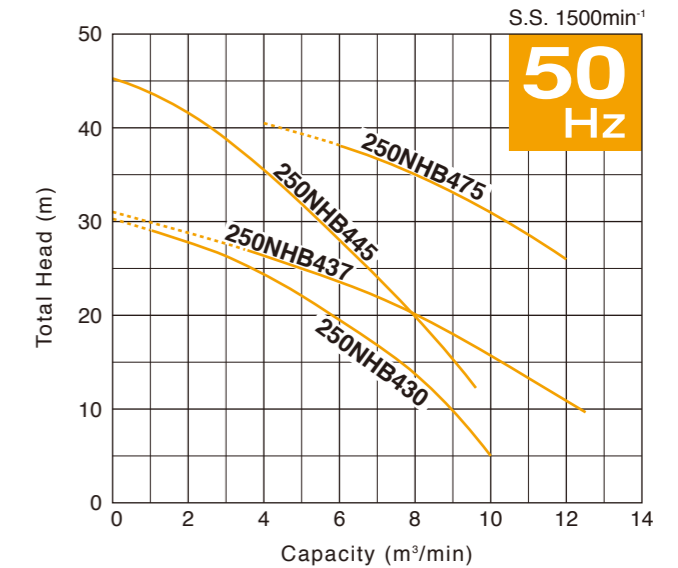

< 300mm >

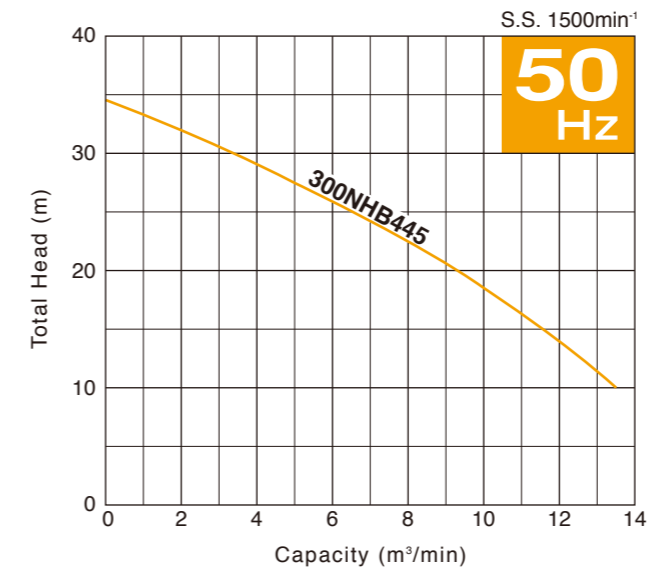

NHC –Cutter Impeller, 2-pole–

The NHC-series is a submersible cutter pump designed for handling raw sewage, wastewater, and heavy-duty industrial applications, where the pump is subject to clogging from oversize material. Two tungsten carbide alloy edges blazed on the impeller vane on the serrated suction cover. This mechanism cuts incoming fibrous material into pieces, permitting smooth passage of fibrous material.



80NHC25.5



TOS80NHC25.5

Discharge Bore mm	Model		Motor Output kW	Starting Method	Solids Passage mm	Dimensions L x H mm		Dry Weight* kg		Cable Length m
	Free Standing	Guide Rail Fitting				Free Standing	Guide Rail Fitting	Free Standing	Guide Rail Fitting	
50	50NHC2.75	TOS50NHC2.75	0.75	D.O.L.	11	380 x 414	596 x 486	26	23	6
50	50NHC21.1	TOS50NHC21.1	1.1	D.O.L.	11	380 x 414	596 x 486	26	23	6
50	50NHC21.5	TOS50NHC21.5	1.5	D.O.L.	10	451 x 468	633 x 534	41	37	6
50	50NHC22.2	TOS50NHC22.2	2.2	D.O.L.	12	451 x 510	633 x 569	44	39	6
50	50NHC23.0	TOS50NHC23.0	3.0	D.O.L.	9	470 x 540	652 x 597	51	47	6
50	50NHC23.7	TOS50NHC23.7	3.7	D.O.L.	20	513 x 557	695 x 611	56	52	6
80	80NHC22.2	TOS80NHC22.2	2.2	D.O.L.	22	517 x 577	691 x 604	55	48	6
80	80NHC23.0	TOS80NHC23.0	3.0	D.O.L.	24	515 x 585	688 x 627	55	48	6
80	80NHC23.7	TOS80NHC23.7	3.7	D.O.L.	22	517 x 610	691 x 637	67	60	6
80	80NHC25.5	TOS80NHC25.5	5.5	D.O.L.	23	615 x 879	788 x 877	115	102	6
80	80NHC27.5	TOS80NHC27.5	7.5	D.O.L.	26	615 x 879	788 x 877	128	115	6
80	80NHC211	TOS80NHC211	11	Star-Delta	26	615 x 927	788 x 925	154	141	8

* All weights excluding cable
Weights of guide rail fitting excluding duckfoot bend

Performance Curves

It is not recommended to operate the unit continuously along the dashed curve.

< 50mm >

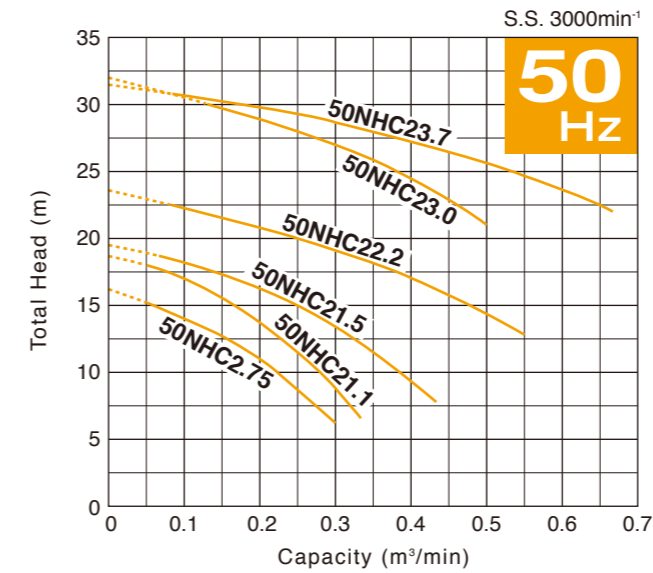

< 80mm >

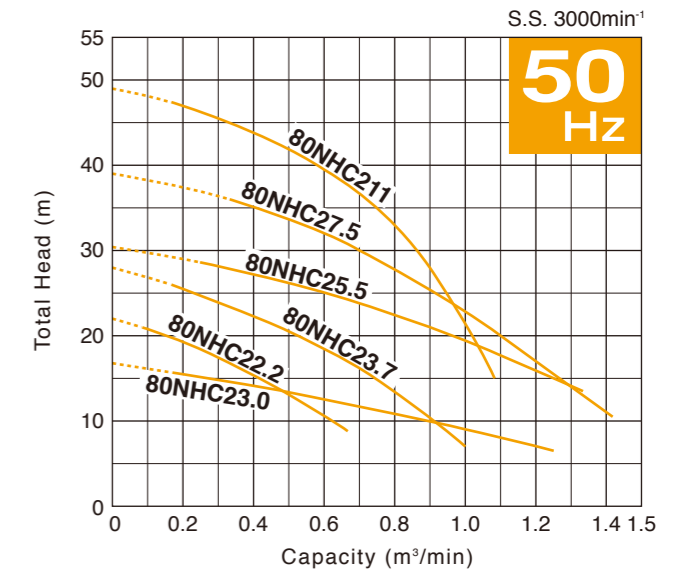

Cutting Mechanism: Impeller & Suction Cover

Two sintered tungsten carbide alloy edges are brazed onto the impeller vane, and they rotate on the serrated part of the suction cover. Incoming fibrous materials are cut up by this mechanism, and this prevents clogging in the pump discharge pipes or valves.



Cutter Pump Operation



NHU –Vortex Impeller, 2-pole–

The NHU-series is a heavy-duty submersible pump equipped with a vortex impeller for pumping sewage and wastewater. The semi-vortex design provides a solids passage that is 70% or more* of the discharge bore, thus reducing troubles caused by the clogging of fibrous solids to a minimum. Rotation of the impeller produces vortex flow in the pump casing, which allows those foreign matters to be pumped out with minimum contact to the impeller.

* excluding model 80NHU21.5



50NHU2.75

80NHU22.2

Discharge Bore mm	Model		Motor Output kW	Starting Method	Solids Passage mm	Dimensions L x H mm		Dry Weight* kg		Cable Length m
	Free Standing	Guide Rail Fitting				Free Standing	Guide Rail Fitting	Free Standing	Guide Rail Fitting	
50	50NHU2.75	TOS50NHU2.75	0.75	D.O.L.	35	364 x 430	580 x 518	25	23	6
50	50NHU21.5	TOS50NHU21.5	1.5	D.O.L.	35	406 x 467	622 x 550	39	37	6
80	80NHU21.5	TOS80NHU21.5	1.5	D.O.L.	46	420 x 490	607 x 578	43	40	6
80	80NHU22.2	TOS80NHU22.2	2.2	D.O.L.	56	502 x 539	641 x 624	50	43	6
80	80NHU23.7	TOS80NHU23.7	3.7	D.O.L.	56	502 x 572	641 x 657	55	48	6

* All weights excluding cable
Weights of guide rail fitting excluding duckfoot bend

Performance Curves

It is not recommended to operate the unit continuously along the dashed curve.

< 50mm >

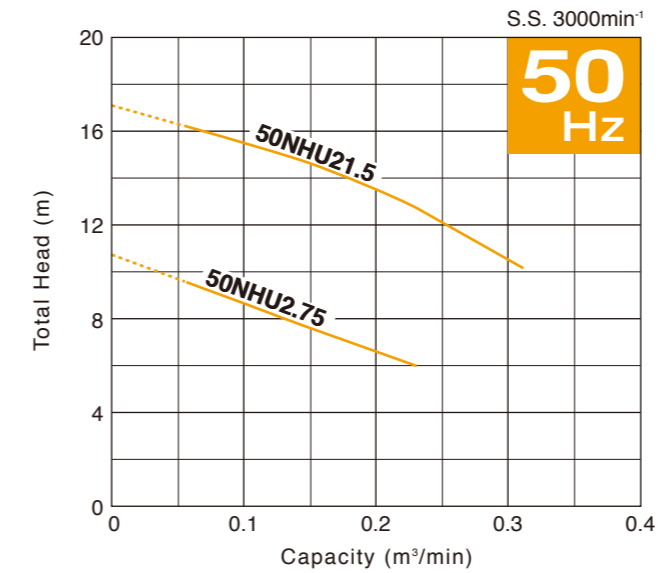

< 80mm >

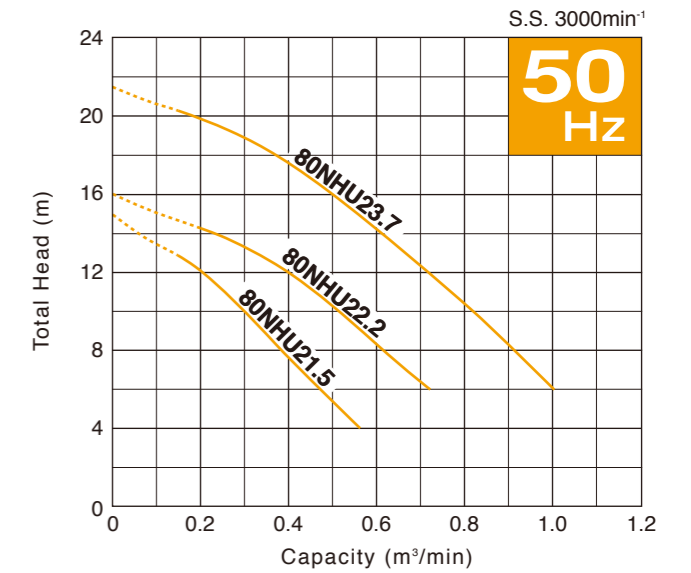

NH –Channel Impeller, 2-pole–

The NH-series is a cast iron made, submersible sewage pump utilizing 2-pole motor. This impeller is a shrouded two-channel impeller. Each channel is designed to have a larger area and it enables the pump to be suitable for pumping wastewater containing a certain size of solids. The pumps are available in six motor sizes ranging from 1.5 to 7.5kW and available in either High Head or High Volume Type.



Performance Curves

It is not recommended to operate the unit continuously along the dashed curve.

< High Head Type >

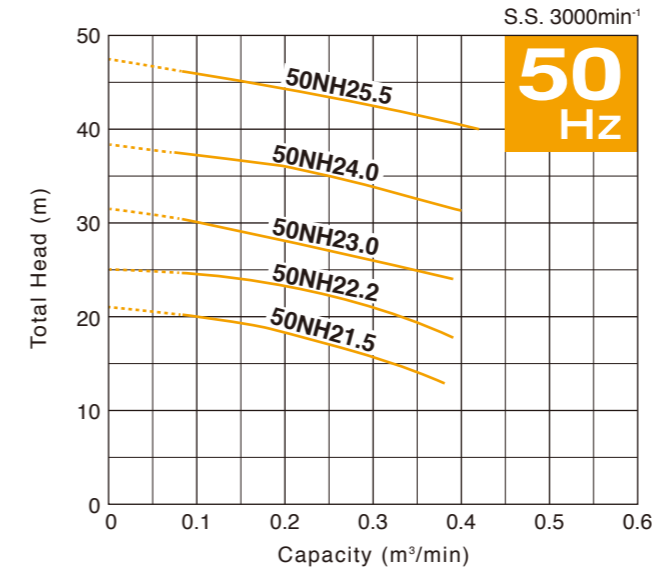

< High Volume Type >

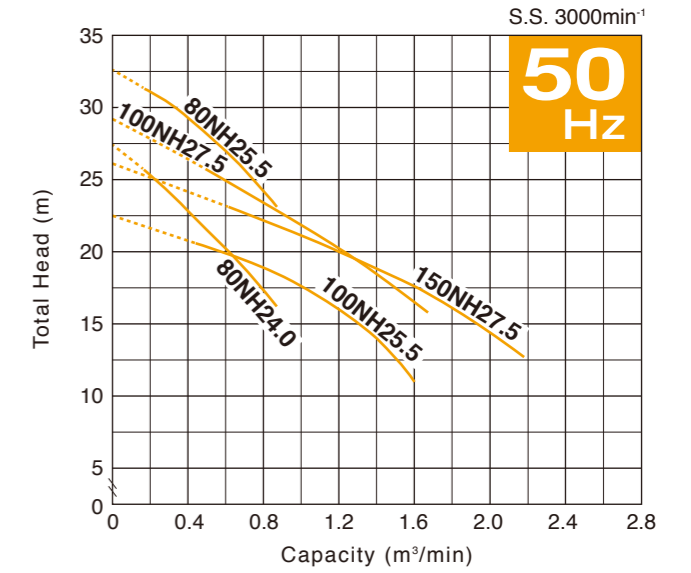

Discharge Bore mm	Model		Motor Output kW	Starting Method	Solids Passage mm	Dimensions L x H mm		Dry Weight* kg		Cable Length m
	Free Standing	Guide Rail Fitting				Free Standing	Guide Rail Fitting	Free Standing	Guide Rail Fitting	
50	50NH21.5	TOS50NH21.5	1.5	D.O.L.	15	446 x 475	628 x 534	39	35	6
50	50NH22.2	TOS50NH22.2	2.2	D.O.L.	17.5	454 x 510	637 x 569	44	39	6
50	50NH23.0	TOS50NH23.0	3.0	D.O.L.	25.5	455 x 540	637 x 597	50	46	6
50	50NH24.0	TOS50NH24.0	4.0	D.O.L.	25.5	496 x 557	679 x 611	56	51	6
50	50NH25.5	TOS50NH25.5	5.5	D.O.L.	19.5	497 x 790	679 x 844	90	86	6
80	80NH24.0	TOS80NH24.0	4.0	D.O.L.	26	522 x 563	696 x 632	61	54	6
80	80NH25.5	TOS80NH25.5	5.5	D.O.L.	17.5	515 x 793	688 x 860	96	89	6
100	100NH25.5	TOS100NH25.5	5.5	D.O.L.	35.5	569 x 835	788 x 913	105	95	6
100	100NH27.5	TOS100NH27.5	7.5	D.O.L.	32.5	597 x 835	816 x 908	114	104	6
150	150NH27.5	TOS150NH27.5	7.5	D.O.L.	31	720 x 850	915 x 976	140	117	6

* All weights excluding cable
Weights of guide rail fitting excluding duckfoot bend



Specifications 50Hz

		NHB								NHB										
		100NHB45.5	100NHB47.5	150NHB47.5L	150NHB411	150NHB415	150NHB422H	150NHB422	150NHB437	150NHB455	200NHB411	200NHB415	200NHB437	200NHB455	200NHB475	250NHB430	250NHB437	250NHB445	250NHB475	300NHB445
PUMP	Discharge Bore mm	100		150						200					250				300	
	Discharge Connection	DIN PN6 Flange (come with Threaded Companion Flange)								DIN PN6 Flange										
	Solids Passage mm	40		60	75			40 x 50	35 x 110		68 x 60	70 x 60	40 x 77	40 x 70	35 x 75	75 x 55	62 x 80	45 x 70	60 x 80	60 x 90
	Impeller	Shrouded One-channel	Shrouded Two-channel	Shrouded One-channel			Shrouded Two-channel			Shrouded Two-channel										
		Radial Gap	Axial Gap					Radial Gap	Axial Gap			Radial Gap	Axial Gap			Radial Gap	Axial Gap			
		Gray Cast Iron								Gray Cast Iron										
	Suction Cover	Gray Cast Iron								Gray Cast Iron										
	Wear Ring	—						Gray Cast Iron		Gray Cast Iron										
	Mouth Ring	—						Gray Cast Iron		Gray Cast Iron										
	Oil Seal	Q'ty	Single					Triple			Single			Triple			Single		Triple	
Nitrile Butadiene Rubber										Nitrile Butadiene Rubber										
Labyrinth Ring	—						304 Stainless Steel		—			304 Stainless Steel			—		304 Stainless Steel		—	
Casing	Gray Cast Iron								Gray Cast Iron											
Shaft Seal	Dual Inside Mechanical Seals (with Oil Lifter)								Dual Inside Mechanical Seals (with Oil Lifter)											
	Silicon Carbide								Silicon Carbide											
MOTOR	Type	Continuous-duty Rated, Dry-type Induction Motor								Continuous-duty Rated, Dry-type Induction Motor										
	Output kW	5.5	7.5	11	15	22	37	55	11	15	37	55	75	30	37	45	75	45		
	Phase	Three								Three										
	Pole	4								4										
	Speed (S.S.) min ⁻¹	1500								1500										
	Insulation	F								F										
	Starting Method	D.O.L.*2		Star-Delta*3			Star-Delta			Star-Delta*3			Star-Delta			Star-Delta*3		Star-Delta		
	Motor Protector (built-in)	CTP		MTP			MTP													
	Leakage Sensor (built-in)	—		Electrode			Electrode													
	Lubricant	ml	4200	4600	5200	5100	4600	9100	9600	5200	5100	9100	9600	8600	9100	9600	9100			
Turbine Oil (ISO VG32)								Turbine Oil (ISO VG32)												
Frame	Gray Cast Iron								Gray Cast Iron											
Shaft	420 Stainless Steel								420 Stainless Steel											
Power Cable	m	6		8						8										
		Chloroprene Rubber										Chloroprene Rubber								
Dry Weight*1	Free Standing kg	145	158	221	243	259	347	547	877	262	287	562	912	992	551	611	711	1050	775	
	Guide Rail Fitting kg	132	145	192	213	234	317	486	838	257	282	503	875	955	473	533	620	995	695	

*1 All weights excluding cable

Weights of guide rail fitting excluding duckfoot bend

*2 Star-Delta available upon request

*3 D.O.L. available upon request

Specifications 50Hz

		NHC											NHU					NH																
		50NHC2.75	50NHC21.1	50NHC21.5	50NHC22.2	50NHC23.0	50NHC23.7	80NHC22.2	80NHC23.0	80NHC23.7	80NHC25.5	80NHC27.5	80NHC211	50NHU2.75	50NHU21.5	80NHU21.5	80NHU22.2	80NHU23.7	50NH21.5	50NH22.2	50NH23.0	50NH24.0	50NH25.5	80NH24.0	80NH25.5	100NH25.5	100NH27.5	150NH27.5						
PUMP	Discharge Bore mm	50						80										50		80			50			80			100		150			
	Discharge Connection	Threaded Oval Flange		JIS 10kg/cm ² Flange																Threaded Oval Flange		JIS 10kg/cm ² Flange												
	Solids Passage mm	11	10	12	9	20	22	24	22	23	26							35	46	56		15	17.5	25.5		19.5	26	17.5	35.5	32.5	31			
	Impeller	Cutter (Semi-open Two-channel Impeller with Two Cutting Edges)																Vortex			Shrouded Two-channel													
		Gray Cast Iron with Tungsten Carbide Alloy																Gray Cast Iron																
	Suction Cover	Ductile Cast Iron																Gray Cast Iron		—			Gray Cast Iron											
	Oil Seal	Q'ty	Single																Single															
			Nitrile Butadiene Rubber																Nitrile Butadiene Rubber															
	Casing	Gray Cast Iron																Gray Cast Iron																
	Shaft Seal	Dual Inside Mechanical Seals (with Oil Lifter)																Dual Inside Mechanical Seals (with Oil Lifter)																
Silicon Carbide																Silicon Carbide																		
MOTOR	Type	Continuous-duty Rated, Dry-type Induction Motor																Continuous-duty Rated, Dry-type Induction Motor																
	Output kW	0.75	1.1	1.5	2.2	3.0	3.7	2.2	3.0	3.7	5.5	7.5	11	0.75	1.5	2.2	3.7	1.5	2.2	3.0	4.0	5.5	4.0	5.5	7.5									
	Phase	Three																Three																
	Pole	2																2																
	Speed (S.S.) min ⁻¹	3000																3000																
	Insulation	F																F																
	Starting Method	D.O.L.									Star-Delta							D.O.L.																
	Motor Protector (built-in)	CTP									MTP							CTP																
	Leakage Sensor (built-in)	—									Electrode							—																
	Lubricant	ml	500	940	1160	1100	1300	1160	1100	1300	2140	2000							500	940	1160	1300	940	1160	1100	1300	2140	1300	2140	2000				
Turbine Oil (ISO VG32)																Turbine Oil (ISO VG32)																		
Frame	Gray Cast Iron																Gray Cast Iron																	
Shaft	420 Stainless Steel																420 Stainless Steel																	
Power Cable	m	6									8							6																
		Chloroprene Rubber																Chloroprene Rubber																
Dry Weight*	Free Standing kg	26	41	44	51	56	55		67	115	128	154						25	39	43	50	55	39	44	50	56	90	61	96	105	114	140		
	Guide Rail Fitting kg	23	37	39	47	52	48		60	102	115	141						23	37	40	43	48	35	39	46	51	86	54	89	95	104	117		

* All weights excluding cable
Weights of guide rail fitting excluding duckfoot bend



We reserve the right to change the specifications and designs for improvement without prior notice.

**TSURUMI
MANUFACTURING CO., LTD.**

Your Dealer